

AD

AIR DIFFUSERS



reddot winner 2023

FRAMELESS DIFFUSERS
TECHNICAL CATALOGUE

ABOUT US

The original idea
makes design distinctive,
the function makes it work
and quality adds value

Serge Zuev



reddot winner 2023

We are a proud winner of a Red Dot Design Award

The internationally-recognised Red Dot Design Awards have been held annually for over 60 years, and recognise the best global contributions to design, assessing function, aesthetics, usage and responsibility.

It is one of the world's largest design competitions. The Red Dot Label has become established internationally as one of the most sought-after marks of quality for good design.

More information on <https://www.red-dot.org>

PRODUCING UNIQUE GYPSUM VENT DIFFUSERS

At Ventmann, we engineer and manufacture innovative, modern vent diffusers. And they all incorporate our first-of-its-kind patented gypsum composite, together with refined designs to complement a range of interiors. In our company, we like to say "air has never been so elegant." We hope that for your project, Ventmann vent diffusers will be your choice for air elegance.

OUR PURPOSE

Each of our products is so much more than just another vent diffuser. They are minimalist interior elements that can be integrated discreetly into any interior, or used to accentuate the precise lines and rigid angles of your design.

We work hard to create, produce and supply next generation solutions to our partners and clients. We have three values that all our products meet:

- They are innovative - our diffusers are the first on the market to be made from our special gypsum composite, so they can be frameless and fit any contemporary design. Our philosophy is that modern interiors need modern vents.
- They are sustainable - gypsum is one of the most sustainable and clean materials in use. Furthermore, we follow an environmentally-friendly production process and use ecological packaging.
- They are elegant - we want our diffusers to maintain the integrity of the interior design, completely blending in with wall and ceiling surfaces.

OUR VISION

We grow together with our partners. That is why we always ensure the highest quality standards for our products. We want our distribution partners to have full confidence when assuring their customers that Ventmann diffusers are the best choice. This commitment to partnership and quality is helping us to achieve our ambition of supplying Ventmann diffusers worldwide.

OUR PLANS FOR GROWTH AND DEVELOPMENT

In addition to continuously developing our distribution network, we are also expanding our production capacity as demand grows. We aim to add more patented diffusers as our manufacturing capabilities expand, which will help us to further grow our partner network and ensure the Ventmann brand is a great choice for partners who want to be the first in bringing innovations to the vent diffuser market.



LINE





FRAMELESS



PLASTERED - IN



PAINTABLE



The Ventmann LINE vent diffuser is an elegant and flexible interior design solution. With this model, you can create strikingly unique interior elements. Or you can make the diffusers virtually invisible. It is your choice.

The Ventmann LINE vent diffuser is available with varying numbers of slots, and in varying sizes. The SLIM version is ideal if you aim to have the diffusers virtually invisible. By contrast, you can also make the diffusers a design feature. For example, our LINE diffusers can be used as imitations to create a continuous line without any breaks.

This is a model that is engineered for practicality. These diffusers, like all of our models, can be painted using the same paint as the other surfaces in the room. This means there are no frames and the diffusers are seamlessly and elegantly integrated. The connections used are simple and unobtrusive, and our LINE model does not require lowering of the ceiling height.

The Ventmann LINE vent diffuser is also versatile. It can be adapted in a range of different ways to suit your project's needs. Our standard LINE vent diffuser is available:

- In 1-slot, 2-slot or 3-slot versions
- In standard lengths of 625mm, 1000mm and 1250mm
- With slot widths of either 12mm or 18mm.

If your project requires non-standard solutions or specific dimensions, we are happy to help.

To see just how easy it is to install the Ventmann LINE vent diffuser, have a look at our product showcase video.

And our catalogue contains all of the technical information about this model, so you can explore all of its possibilities and see how it would fit with your project.



LINE / PLINE



CIRCLE / PCIRCLE



SQUARE



ART



Installation:
video instructions



Download a digital
version of the catalog



LINE SERIES TECHNICAL PARAMETERS

SUPPLY

m³/h	dim (mm)	625 1 18	625 1 18D	625 2 18	625 2 18D	625 3 18	625 3 18D	1000 1 18	1000 1 18	1000 2 18	1000 2 18	1000 3 18	1000 3 18	1250 1 18
	Ak (m²)	0,0067	0,00579	0,0134	0,01158	0,02	0,0173	0,0107	0,00926	0,0214	0,0185	0,0321	0,0278	0,0135
60	X (m)	1,8	2		1,3				1,2					
	Pt (Pa)	4	10		3				3					
	SPLA (dB (A))	<20	<20		<20				<20					
80	X (m)	2,4	2,7	1,6	1,8		0,8		1,6					
	Pt (Pa)	6	15	2	5		3		8					
	SPLA (dB (A))	<20	<20	<20	<20		<20		<20					
100	X (m)	2,9	3,3	2	2,2		1	1,8	2		1,2			
	Pt (Pa)	9	23	3	9		4	4	13		2			
	SPLA (dB (A))	<20	<20	<20	<20		<20	<20	<20		<20			
160	X (m)	4,7	5,3	3,1	3,6	1,4	1,6	2,8	3,1		1,9		1,3	2,6
	Pt (Pa)	21	59	5	21	3	10	6	30		9		2	2
	SPLA (dB (A))	<20	21	<20	<20	<20	<20	<20	<20		<20		<20	<20
200	X (m)	5,9	6,7	3,9	4,4	1,8	2	3,5	3,9	2	2,4		1,6	3,3
	Pt (Pa)	36	93	9	31	4	15	9	47	3	15		5	5
	SPLA (dB (A))	23	26	<20	<20	<20	<20	<20	<20	<20	<20		<20	<20
300	X (m)	8,8		5,9	6,7	2,6	3	5,3	5,9	3	3,6	2,2	2,4	4,9
	Pt (Pa)	82		24	72	10	35	19	105	6	32	3	16	12
	SPLA (dB (A))	32		<20	22	<20	<20	24	26	<20	<20	<20	<20	<20
400	X (m)			7,8		3,5	4	7		4	4,8	2,9	3,2	6,6
	Pt (Pa)			44		17	60	37		10	55	6	27	22
	SPLA (dB (A))			26		<20	22	30		<20	21	<20	<20	26
500	X (m)			9,8		4,4	5	8,8		5	6	3,6	4	8,2
	Pt (Pa)			70		27	90	61		17	85	9	41	33
	SPLA (dB (A))			31		24	27	35		23	25	<20	<20	31
600	X (m)					5,3		10,5		5,9		4,4	4,8	9,8
	Pt (Pa)					37		92		26		13	60	48
	SPLA (dB (A))					28		39		27		<20	22	35
700	X (m)					6,1				6,9		5,1	5,6	11,5
	Pt (Pa)					50				37		19	82	67
	SPLA (dB (A))					31				30		23	26	38
800	X (m)									7,9		5,8		13,1
	Pt (Pa)									49		26		95
	SPLA (dB (A))									33		26		41
900	X (m)									8,9				
	Pt (Pa)									63				
	SPLA (dB (A))									36				
1000	X (m)									9,9				
	Pt (Pa)									80				
	SPLA (dB (A))									38				

D - deflector for 18mm only

X (m) - Throw distance (0,25 m/s)

SPLA (dB(A)) - Sound pressure level at 1m distance

Ak (m²) - effective area

Pt (Pa) - Pressure drop in the diffuser

from the diffuser

	Green	Yellow	Red
X (m)	When short throw distance is needed	When average throw distance is needed	When bigger throw distance is needed
Pa	Where low pressure drop is required	Where medium pressure drop is suitable	Where big pressure drop is suitable
SPLA	Rooms with no ambient noise (Bedroom)	Rooms with medium ambient noise (Lobby)	Rooms with ambient noise (Office room)

* IMPORTANT: This information is for guidance only, please consult your HVAC professional for you specific requirements.

m ³ /h	dim (mm)	1250 1 18D	1250 2 18	1250 2 18D	1250 3 18	1250 3 18D	625 1 12	625 2 12	625 3 12	1000 1 12	1000 2 12	1000 3 12	1250 1 12	1250 2 12	1250 3 12
	Ak (m ²)	0,01162	0,027	0,0232	0,0405	0,03486	0,00444	0,00888	0,0133	0,0071	0,0142	0,0213	0,0144	0,0288	0,0432
60	X (m)	1,1					1,8								
	Pt (Pa)	2					4								
	SPLA (dB (A))	<20					<20								
80	X (m)	1,5					2,4	1,2		1,4					
	Pt (Pa)	5					7	3		2					
	SPLA (dB (A))	<20					<20	<20		<20					
100	X (m)	1,9					3	1,4		1,7					
	Pt (Pa)	9					11	4		4					
	SPLA (dB (A))	<20					<20	<20		<20					
160	X (m)	3		1,5			4,8	2,3	2,1	2,8	1,6		2,4		
	Pt (Pa)	20		6			29	11	5	10	2		5		
	SPLA (dB (A))	<20		<20			25	<20	<20	<20	<20		<20		
200	X (m)	3,8	1,7	1,9			6,1	2,9	2,6	3,4	2		3	1,9	
	Pt (Pa)	30	2	9			45	18	7	15	4		9	3	
	SPLA (dB (A))	<20	<20	<20			30	<20	<20	22	<20		<20	<20	
300	X (m)	5,7	2,5	2,9		2,2	9,1	4,3	3,9	5,2	3	1,9	4,5	2,8	2,4
	Pt (Pa)	65	4	20		9	95	38	17	34	11	5	20	6	4
	SPLA (dB (A))	22	<20	<20		<20	39	27	20	31	<20	<20	<20	<20	<20
400	X (m)		3,3	3,8	2,4	2,9		5,8	5,3	6,9	4	2,5	6,1	3,7	3,2
	Pt (Pa)		7	35	3	16		72	29	62	20	10	35	11	6
	SPLA (dB (A))		<20	<20	<20	<20		33	26	37	25	<20	25	<20	<20
500	X (m)		4,2	4,8	2,9	3,7			6,6	8,6	5	3,1	7,6	4,6	4
	Pt (Pa)		12	54	5	26			45	95	30	17	52	18	10
	SPLA (dB (A))		<20	22	<20	<20			31	42	30	23	30	<20	<20
600	X (m)		5	5,7	3,5	4,4			7,9		6	3,8	9,1	5,6	4,8
	Pt (Pa)		17	75	7	36			64		45	25	76	27	15
	SPLA (dB (A))		23	25	<20	<20			35		34	27	34	22	<20
700	X (m)		5,8		4,1	5,1			9,2		7	4,4		6,5	5,6
	Pt (Pa)		24		10	50			95		65	35		37	22
	SPLA (dB (A))		26		<20	22			38		37	30		25	<20
800	X (m)				4,7	5,9					8	5		7,4	6,3
	Pt (Pa)				13	67					88	46		49	30
	SPLA (dB (A))				22	25					40	33		28	21
900	X (m)				5,3	6,6						5,7		8,3	7,1
	Pt (Pa)				16	85						60		63	40
	SPLA (dB (A))				25	27						36		31	23
1000	X (m)				5,9	7,4						6,3			7,9
	Pt (Pa)				20	115						75			52
	SPLA (dB (A))				27	29						38			26

LINE SERIES TECHNICAL PARAMETERS

EXHAUST

m³/h	dim (mm)	625 1 18	625 2 18	625 3 18	1000 1 18	1000 2 18	1000 3 18	1250 1 18	1250 2 18	1250 3 18
	Ak (m²)	0,0067	0,0134	0,02	0,0107	0,0214	0,0321	0,0135	0,027	0,0405
60	Pt (Pa)	2	1							
	SPLA (dB (A))	<20	<20							
80	Pt (Pa)	4	2							
	SPLA (dB (A))	<20	<20							
100	Pt (Pa)	6	2	2	2					
	SPLA (dB (A))	<20	<20	<20	<20					
160	Pt (Pa)	16	4	4	5			2		
	SPLA (dB (A))	<20	<20	<20	<20			<20		
200	Pt (Pa)	25	6	7	8			4		
	SPLA (dB (A))	23	<20	<20	<20			<20		
300	Pt (Pa)	60	14	12	18	3		11	3	
	SPLA (dB (A))	32	<20	<20	24	<20		<20	<20	
400	Pt (Pa)	105	24	17	33	6	4	20	5	2
	SPLA (dB (A))	38	26	<20	30	<20	<20	26	<20	<20
500	Pt (Pa)		37	24	51	10	5	30	8	3
	SPLA (dB (A))		31	24	35	23	<20	31	<20	<20
600	Pt (Pa)		56	33	80	15	7	42	12	4
	SPLA (dB (A))		35	28	39	27	<20	35	23	<20
700	Pt (Pa)					21	9	58	16	6
	SPLA (dB (A))					30	23	38	26	<20
800	Pt (Pa)					28	12	80	22	8
	SPLA (dB (A))					33	26	41	29	22
900	Pt (Pa)						15			11
	SPLA (dB (A))						29			25
1000	Pt (Pa)									14
	SPLA (dB (A))									27

D - deflector for 18mm only

Ak (m²) - effective area

Pt (Pa) - Pressure drop in the diffuser

SPLA (dba) - Sound pressure level at 1m distance from the diffuser

	Green	Yellow	Red
X (m)	When short throw distance is needed	When average throw distance is needed	When bigger throw distance is needed
Pa	Where low pressure drop is required	Where medium pressure drop is suitable	Where big pressure drop is suitable
SPLA	Rooms with no ambient noise (Bedroom)	Rooms with medium ambient noise (Lobby)	Rooms with ambient noise (Office room)

* IMPORTANT: This information is for guidance only, please consult your HVAC professional for you specific requirements.

m ³ /h	dim (mm)	625 1 12	625 2 12	625 3 12	1000 1 12	1000 2 12	1000 3 12	1250 1 12	1250 2 12	1250 3 12
	Ak (m ²)	0,00444	0,00888	0,0133	0,0071	0,0142	0,0213	0,0144	0,0288	0,0432
60	Pt (Pa)	4								
	SPLA (dB (A))	<20								
80	Pt (Pa)	6								
	SPLA (dB (A))	<20								
100	Pt (Pa)	10	3		3					
	SPLA (dB (A))	<20	<20		<20					
160	Pt (Pa)	25	7	4	8			3		
	SPLA (dB (A))	25	<20	<20	<20			<20		
200	Pt (Pa)	39	12	5	13	4		6	2	
	SPLA (dB (A))	30	<20	<20	22	<20		<20	<20	
300	Pt (Pa)	84	28	10	30	9	4	16	4	2
	SPLA (dB (A))	39	27	20	31	<20	<20	<20	<20	<20
400	Pt (Pa)		49	19	56	16	8	29	7	4
	SPLA (dB (A))		33	26	37	25	<20	25	<20	<20
500	Pt (Pa)		77	30	88	26	12	45	11	6
	SPLA (dB (A))		38	31	42	30	23	30	<20	<20
600	Pt (Pa)			45		37	18	65	17	9
	SPLA (dB (A))			35		34	27	34	22	<20
700	Pt (Pa)					52	25	93	25	13
	SPLA (dB (A))					37	30	37	25	<20
800	Pt (Pa)					72	33		34	18
	SPLA (dB (A))					40	33		28	21
900	Pt (Pa)						42		45	24
	SPLA (dB (A))						36		31	23
1000	Pt (Pa)						53			31
	SPLA (dB (A))						38			26

LINE 1/12



1 AMOUNT OF SLOTS 12 mm WIDTH OF SLOT

2.5 kg
1 M. LENGTH DIFFUSER WEIGHT
WITHOUT PACKAGING (NET)

625 / 1000 / 1250
STANDARD SLOT LENGTH (MM)

A PLENUM BOX
CONNECTION TYPE

Steel punched sheet. Distributes the air supply through the diffuser.

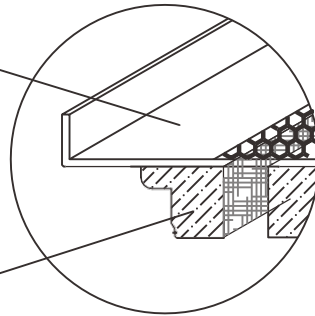

Gypsum mix segment. Sanded, puttied, painted. Suitable for all operations in combination with surface finishing

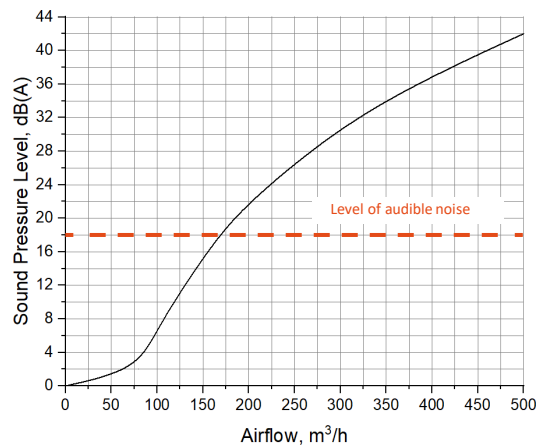
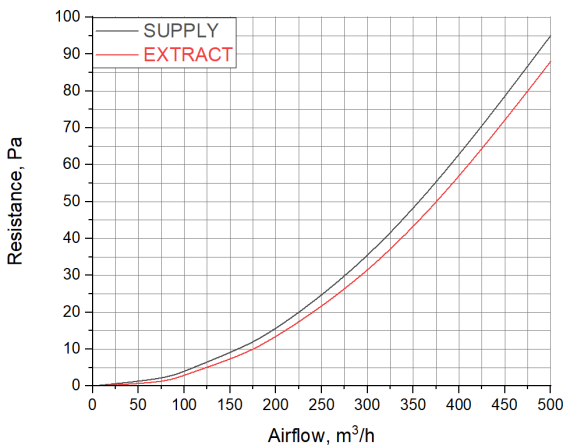
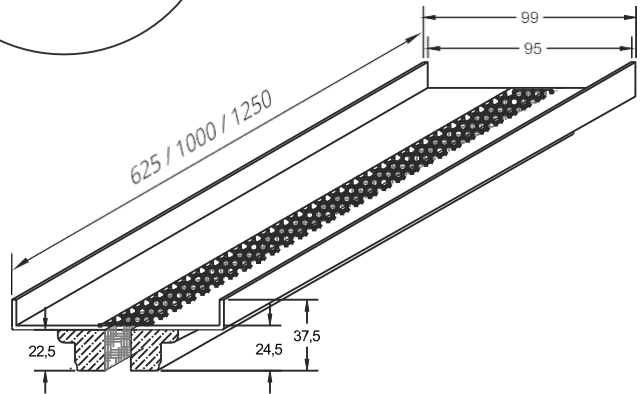
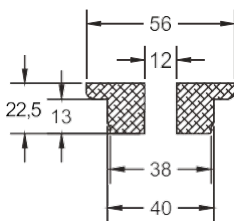

Note: Data charts reflect measurements for the 1 m length model.

LINE 1/18



1 AMOUNT OF SLOTS
18 mm WIDTH OF SLOT

2.5 kg
 1 M. LENGTH DIFFUSER WEIGHT
 WITHOUT PACKAGING (NET)

625 / 1000 / 1250
 STANDARD SLOT LENGTH (MM)

OPTIONAL:
Deflector

SPECIAL CONSTRUCTION, CAN BE
 ADDED ANYTIME LATER

A PLENUM BOX
 CONNECTION TYPE

Steel punched sheet. Distributes the air supply through the diffuser.

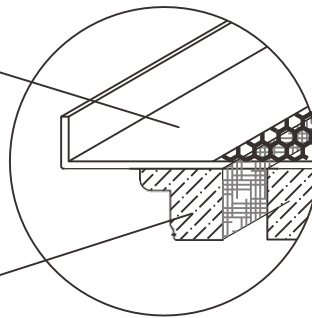

Gypsum mix segment. Sanded, puttied, painted. Suitable for all operations in combination with surface finishing

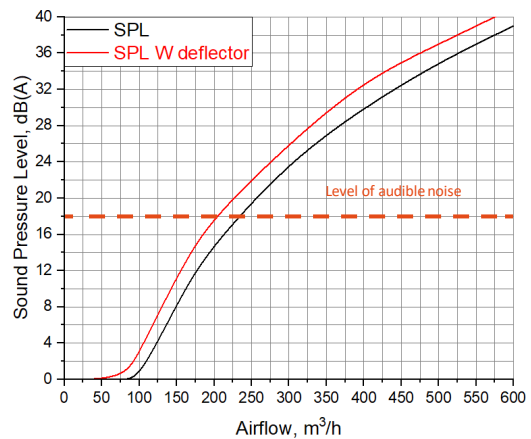
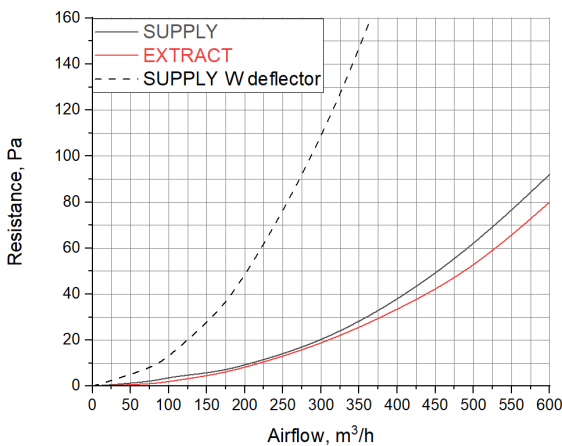
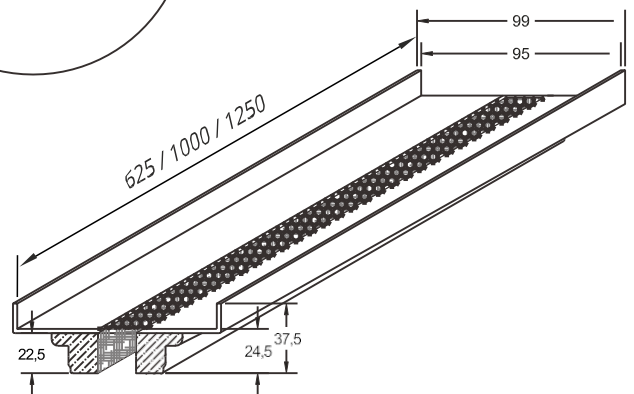
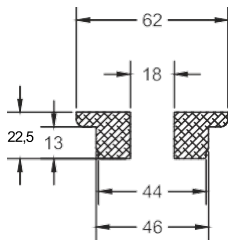

Note: Data charts reflect measurements for the 1 m length model.

LINE 2/12



2 AMOUNT OF SLOTS 12 mm WIDTH OF SLOT

2.735 kg

1 M. LENGTH DIFFUSER WEIGHT WITHOUT PACKAGING (NET)

625 / 1000 / 1250 STANDARD SLOT LENGTH (MM)

A PLENUM BOX CONNECTION TYPE

Steel punched sheet. Distributes the air supply through the diffuser.

Gypsum mix segment. Sanded, puttied, painted. Suitable for all operations in combination with surface finishing

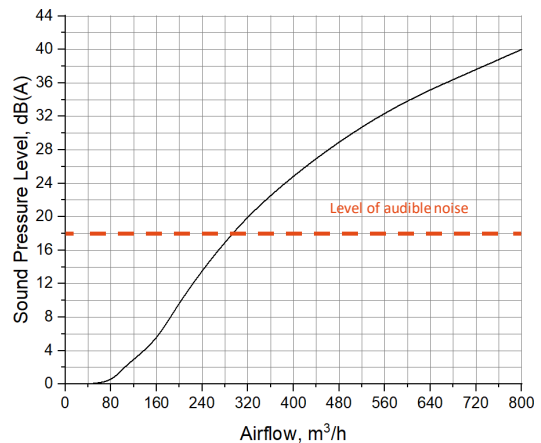
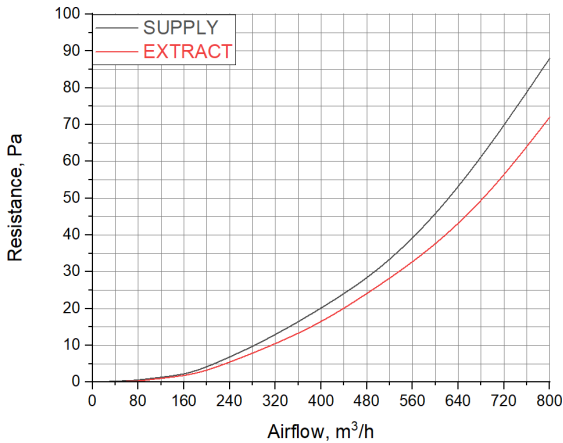
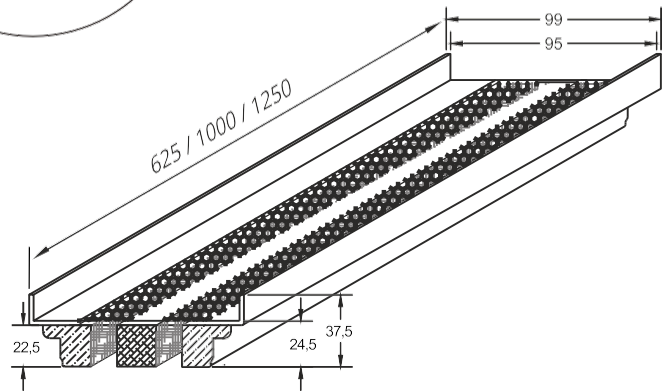
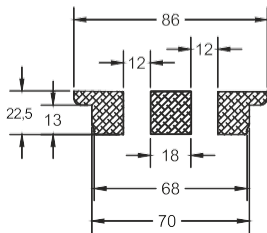
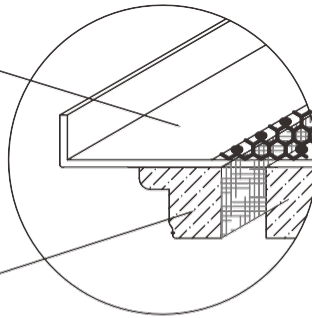

Note: Data charts reflect measurements for the 1 m length model.

LINE 3/12



3 AMOUNT OF SLOTS **12 mm** WIDTH OF SLOT

4.085 kg
1 M. LENGTH DIFFUSER WEIGHT
WITHOUT PACKAGING (NET)

625 / 1000 / 1250
STANDARD SLOT LENGTH (MM)

B PLENUM BOX
CONNECTION TYPE

Steel punched sheet. Distributes the air supply through the diffuser.

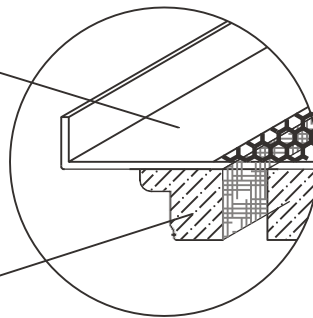

Gypsum mix segment. Sanded, puttied, painted. Suitable for all operations in combination with surface finishing

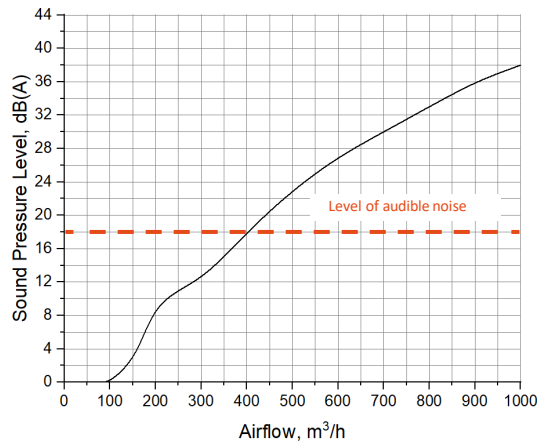
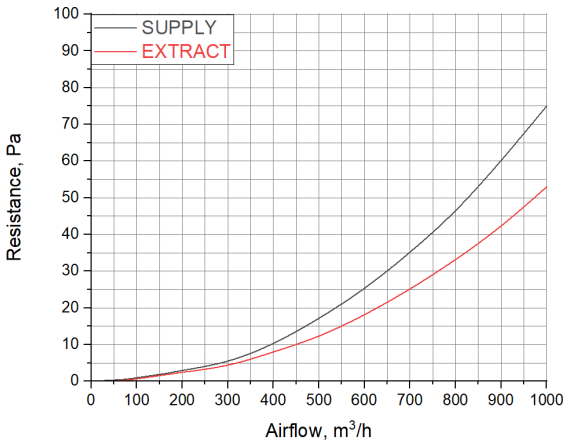
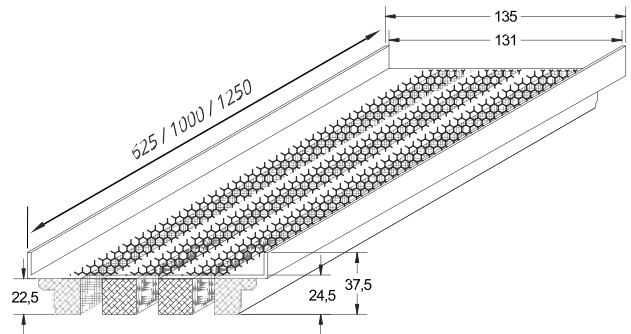
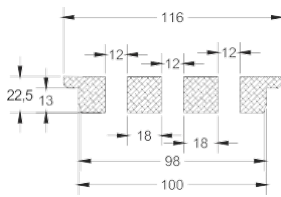

Note: Data charts reflect measurements for the 1 m length model.

LINE 3/18



3 AMOUNT OF SLOTS **18 mm** WIDTH OF SLOT

4.085 kg
1 M. LENGTH DIFFUSER WEIGHT
WITHOUT PACKAGING (NET)

625 / 1000 / 1250
STANDARD SLOT LENGTH (MM)

OPTIONAL:
Deflector

SPECIAL CONSTRUCTION, CAN BE
ADDED ANYTIME LATER

B PLENUM BOX
CONNECTION TYPE

Steel punched sheet. Distributes the air supply
through the diffuser.

Gypsum mix segment. Sanded, puttied,
painted. Suitable for all operations in
combination with surface finishing

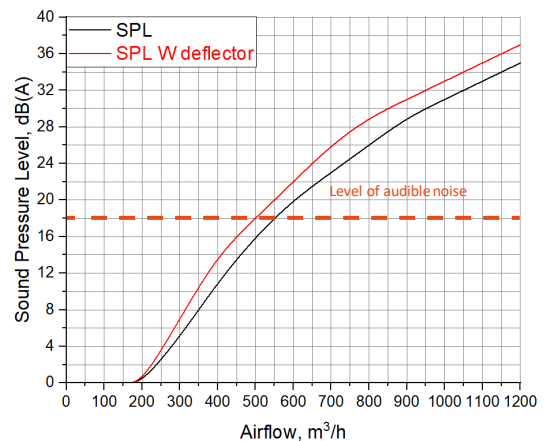
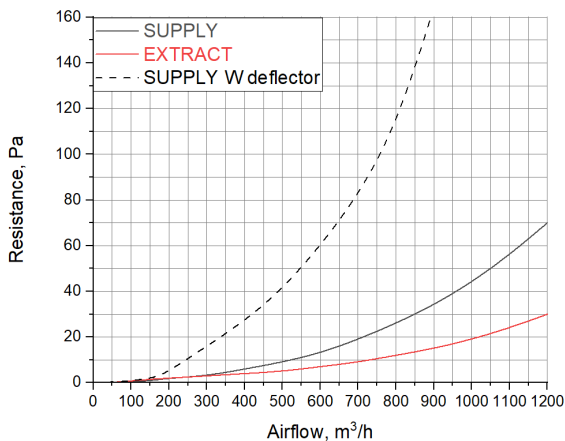
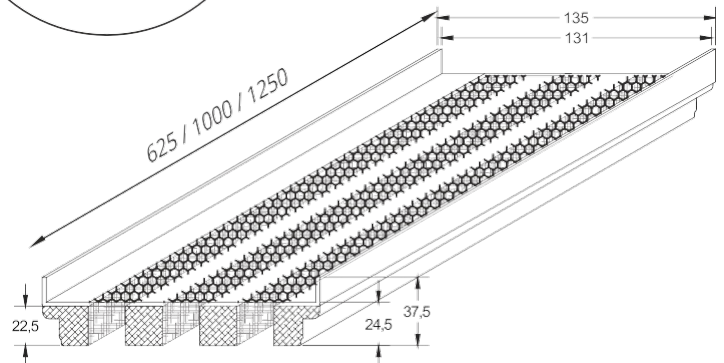
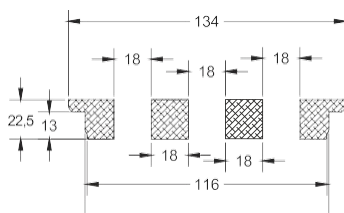
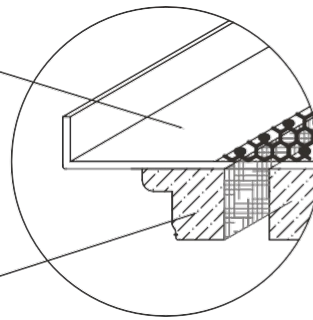

Note: Data charts reflect measurements for the 1 m length model.

PLINE



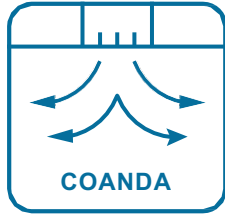

The Ventmann PERFORMANCE LINE vent diffuser combines elegant and adaptable design features with a specially engineered airflow that uses the Coanda effect, making it ideal for air conditioning. This is a model that empowers you to craft distinctive interior features or seamlessly conceal the diffusers, while minimizing direct airflow onto users.

The PERFORMANCE LINE model features all the hallmarks of a Ventmann diffuser - sustainable materials, frameless installation, the ability to paint it to match the other surfaces in the space, and design applications ranging from discrete to bold. What sets it apart from our standard LINE model is its unique shape and engineering, which harness the Coanda effect.

The Coanda effect is an aerodynamic phenomenon that causes a jet of air to be attracted to a nearby surface, efficiently diffusing the airflow. In practice, this means the current of air spreads out along the ceiling rather than being blown straight down.

This innovative vent diffuser also incorporates an interior deflector, adjustable using a simple screwdriver. This deflector enables precise control over the direction of the airflow, allowing you to direct the air at any desired angle from one side to the other. As a result, building users do not experience the discomfort of having a strong airflow directed right at them, which is especially important with air conditioning systems and when dealing with colder air. Ideal for air conditioning use, this model is also suitable for regular ventilation systems and heat recovery units.

As with all Ventmann diffusers, this is a highly flexible and adaptable unit. Our PERFORMANCE LINE vent diffuser is offered in:

- 1-slot, 2-slot, or 3-slot versions
- Standard lengths of 625mm, 1000mm, and 1250mm
- Slot width of 20mm

To see just how easy it is to install the Ventmann PERFORMANCE LINE vent diffuser, have a look at our product showcase video. And our catalogue contains all of the technical information about this model, so you can explore all of its possibilities and see how it would fit with your project.



LINE / PLINE



CIRCLE / PCIRCLE



SQUARE



ART



Installation:
video instructions
 YouTube



Download a digital
version of the catalog
 Download

PERFORMANCE LINE SERIES TECHNICAL PARAMETERS

SUPPLY

m ³ /h	dim (mm)	625 1	625 2	625 3	1000 1	1000 2	1000 3	1250 1	1250 2	1250 3
	Ak (m ²)	0,00708	0,0142	0,0212	0,0116	0,0232	0,0348	0,0146	0,0292	0,0438
60	X (m)	2.4	1.9							
	Pt (Pa)	1	1							
	SPLA (dB (A))	<20	<20							
80	X (m)	3.2	2.5							
	Pt (Pa)	4	2							
	SPLA (dB (A))	<20	<20							
100	X (m)	4.0	3.1	2.9	3.0	2.3	1.5	2.9	2.2	1.2
	Pt (Pa)	8	4	2	2	2	1	2	2	1
	SPLA (dB (A))	<20	<20	<20	<20	<20	<20	<20	<20	<20
160	X (m)	6.4	5.0	4.7	4.9	3.7	2.5	4.5	3.5	2.0
	Pt (Pa)	21	11	5	11	4	2	8	4	2
	SPLA (dB (A))	<20	<20	<20	<20	<20	<20	<20	<20	<20
200	X (m)	8.0	6.3	5.9	6.1	4.7	3.1	5.8	4.3	2.5
	Pt (Pa)	37	16	8	17	7	3	11	6	3
	SPLA (dB (A))	22	<20	<20	<20	<20	<20	<20	<20	<20
300	X (m)	12.0	9.4	8.8	9.1	7.0	4.6	8.7	6.5	3.7
	Pt (Pa)	80	34	16	39	16	7	26	11	6
	SPLA (dB (A))	31	<20	<20	22	<20	<20	<20	<20	<20
400	X (m)	16.0	12.5	11.8	12.2	9.3	6.2	11.6	8.6	4.9
	Pt (Pa)	145	65	27	72	27	13	46	20	10
	SPLA (dB (A))	37	25	<20	29	<20	<20	25	<20	<20
500	X (m)	20.0	15.6	14.7	15.2	11.6	7.7	14.5	10.8	6.2
	Pt (Pa)	242	110	42	112	43	21	73	32	16
	SPLA (dB (A))	42	30	23	34	22	<20	30	<20	<20
600	X (m)		18.8	17.6		14.0	9.2		12.9	7.4
	Pt (Pa)		160	61		63	30		46	22
	SPLA (dB (A))		34	27		25	<20		21	<20
700	X (m)			20.6		16.3	10.8		15.1	8.6
	Pt (Pa)			79		93	40		63	29
	SPLA (dB (A))			30		29	22		25	<20
800	X (m)						12.3			9.9
	Pt (Pa)						52			37
	SPLA (dB (A))						25			21
900	X (m)						13.8			11.1
	Pt (Pa)						63			45
	SPLA (dB (A))						27			23
1000	X (m)						15.4			12.3
	Pt (Pa)						77			55
	SPLA (dB (A))						30			26

X (m) - Throw distance (0,25 m/s)

Pt (Pa) - Pressure drop in the diffuser

SPLA (dba) - Sound pressure level at 1m distance
from the diffuser

Ak (m²) - effective area

	Green	Yellow	Red
X (m)	When short throw distance is needed	When average throw distance is needed	When bigger throw distance is needed
Pa	Where low pressure drop is required	Where medium pressure drop is suitable	Where big pressure drop is suitable
SPLA	Rooms with no ambient noise (Bedroom)	Rooms with medium ambient noise (Lobby)	Rooms with ambient noise (Office room)

* IMPORTANT: This information is for guidance only, please consult your HVAC professional for you specific requirements.

EXHAUST

m ³ /h	dim (mm)	625	625	625	625	625	625	625	625	625	1000	1000	1000	1000	1000
		1 N	1 P	1 D	2 N	2 P	2 D	3 N	3 P	3 D	1 N	1 P	1 D	2 N	2 P
	Ak (m ²)	0,0118	0,00886	0,0071	0,0236	0,0177	0,0142	0,0354	0,0266	0,0212	0,0193	0,0146	0,0116	0,0386	0,0291
60	Pt (Pa)			2			1			2					
	SPLA (dB (A))			<20			<20			<20					
80	Pt (Pa)	1	2	6		1	4		1	3			2		
	SPLA (dB (A))	<20	<20	<20		<20	<20		<20	<20			<20		
100	Pt (Pa)	2	6	12	1	2	6		2	4		1	4	1	2
	SPLA (dB (A))	<20	<20	<20	<20	<20	<20		<20	<20		<20	<20	<20	<20
160	Pt (Pa)	11	17	39	2	4	16	2	4	9	2	6	17	2	3
	SPLA (dB (A))	<20	<20	<20	<20	<20	<20	<20	<20	<20	<20	<20	<20	<20	<20
200	Pt (Pa)	19	28	65	5	7	27	4	6	14	6	9	26	3	4
	SPLA (dB (A))	<20	<20	22	<20	<20	<20	<20	<20	<20	<20	<20	<20	<20	<20
300	Pt (Pa)	44	61	149	12	17	63	7	9	29	15	22	59	5	7
	SPLA (dB (A))	22	27	31	<20	<20	<20	<20	<20	<20	<20	<20	22	<20	<20
400	Pt (Pa)	78	105	303	21	29	120	12	15	49	29	41	112	8	12
	SPLA (dB (A))	28	33	37	<20	21	25	<20	<20	<20	20	25	29	<20	<20
500	Pt (Pa)	123	171		33	45	190	18	23	75	44	66	165	12	18
	SPLA (dB (A))	33	38		21	26	30	<20	<20	23	25	30	34	<20	<20
600	Pt (Pa)				46	64		25	32	120	66	99		17	25
	SPLA (dB (A))				25	30		<20	23	27	29	34		<20	22
700	Pt (Pa)				64	94		34	44		89			23	35
	SPLA (dB (A))				29	34		21	26		32			20	25
800	Pt (Pa)							45							
	SPLA (dB (A))							24							
900	Pt (Pa)														
	SPLA (dB (A))														
1000	Pt (Pa)														
	SPLA (dB (A))														

m ³ /h	dim (mm)	1000	1000	1000	1000	1250	1250	1250	1250	1250	1250	1250	1250	
		2 D	3 N	3 P	3 D	1 N	1 P	1 D	2 N	2 P	2 D	3 N	3 P	3 D
	Ak (m ²)	0,0232	0,0579	0,0437	0,0348	0,0243	0,0202	0,0146	0,0486	0,0404	0,0292	0,0729	0,0606	0,0438
60	Pt (Pa)													
	SPLA (dB (A))													
80	Pt (Pa)	1												
	SPLA (dB (A))	<20												
100	Pt (Pa)	3		1	2		1	3			1			2
	SPLA (dB (A))	<20		<20	<20		<20	<20			<20			<20
160	Pt (Pa)	7		2	4	1	2	7			1			3
	SPLA (dB (A))	<20		<20	<20	<20	<20	<20			<20			<20
200	Pt (Pa)	12	2	3	6	2	4	15	1	2	8			4
	SPLA (dB (A))	<20	<20	<20	<20	<20	<20	<20	<20	<20	<20			<20
300	Pt (Pa)	25	3	5	12	7	13	35	2	4	17	2	2	8
	SPLA (dB (A))	<20	<20	<20	<20	<20	<20	<20	<20	<20	<20	<20	<20	<20
400	Pt (Pa)	43	5	8	20	15	25	65	3	7	29	3	3	15
	SPLA (dB (A))	<20	<20	<20	<20	<20	<20	25	<20	<20	<20	<20	<20	<20
500	Pt (Pa)	67	7	11	31	25	40	100	5	11	46	4	5	23
	SPLA (dB (A))	22	<20	<20	<20	21	24	30	<20	<20	<20	<20	<20	<20
600	Pt (Pa)	99	10	14	45				9	18	65	5	7	32
	SPLA (dB (A))	25	<20	<20	<20				<20	<20	21	<20	<20	<20
700	Pt (Pa)	153	14	18	59				15	29	89	7	9	42
	SPLA (dB (A))	29	<20	<20	22				<20	<20	25	<20	<20	<20
800	Pt (Pa)		19	23	75							9	12	54
	SPLA (dB (A))		<20	21	25							<20	<20	21
900	Pt (Pa)		26	33								12	15	67
	SPLA (dB (A))		<20	23								<20	<20	23
1000	Pt (Pa)		33	42								16	20	82
	SPLA (dB (A))		21	26								<20	<20	26

D - with deflector P - perforated deflector N - no deflector

PLINE 1/20

PERFORMANCE



1 AMOUNT OF SLOTS 20 mm WIDTH OF SLOT

2,45 kg

1 M. LENGTH DIFFUSER WEIGHT WITHOUT PACKAGING (NET)

625 / 1000 / 1250 STANDARD SLOT LENGTH (MM)

DEFLECTOR OPTIONS:

Standart / Perforated / No deflector

A PLENUM BOX WIDTH TYPE

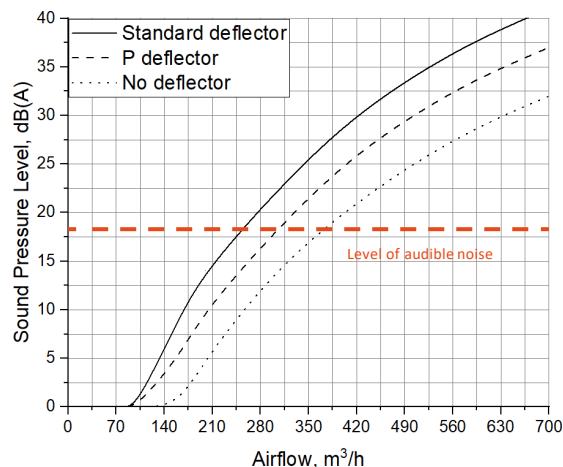
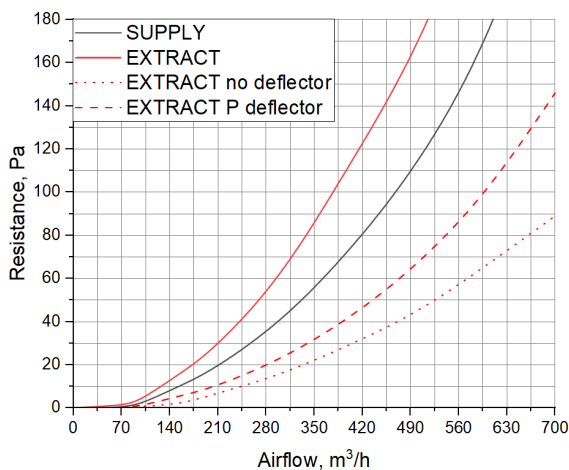
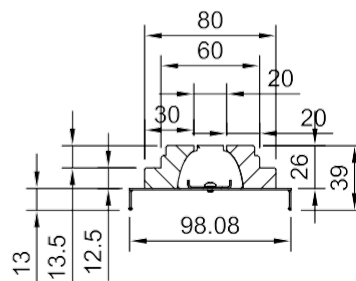
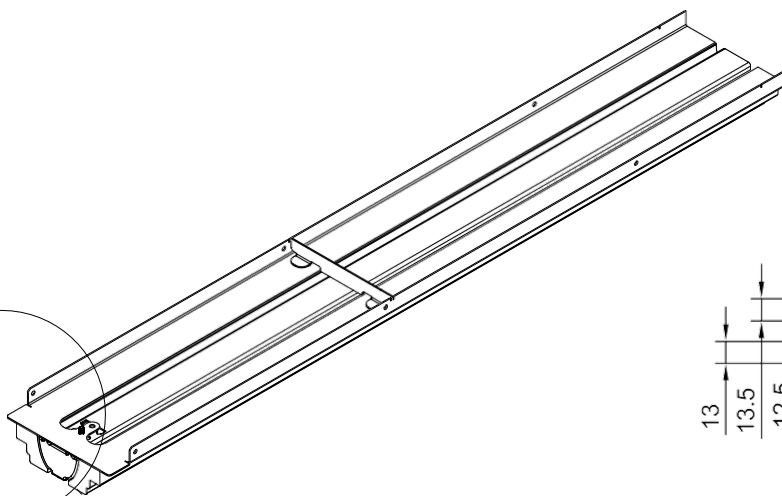
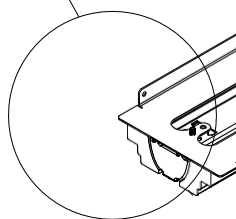
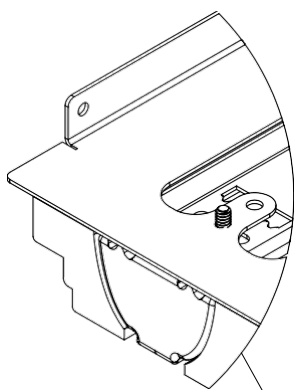

Note: Data charts reflect measurements for the 1 m length model.

PLINE 2/20

PERFORMANCE



2 AMOUNT OF SLOTS **20 mm** WIDTH OF SLOT

3,6 kg
1 M. LENGTH DIFFUSER WEIGHT
WITHOUT PACKAGING (NET)

625 / 1000 / 1250
STANDARD SLOT LENGTH (MM)

DEFLECTOR OPTIONS:
Standart / Perforated
/ No deflector

B PLENUM BOX
WIDTH TYPE

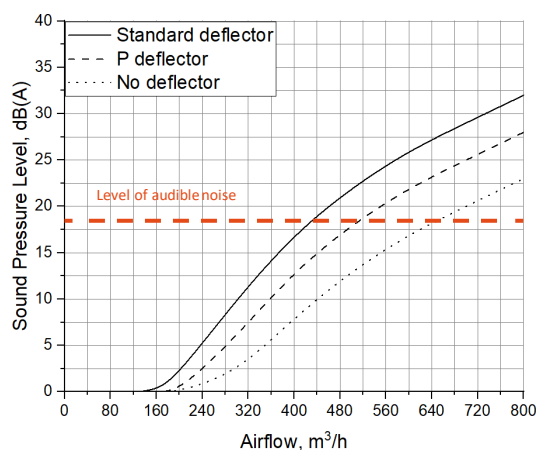
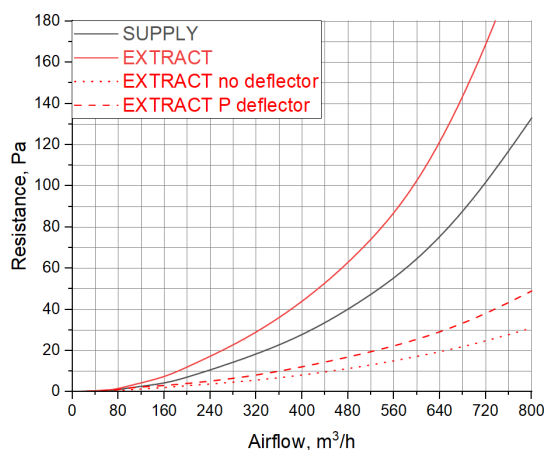
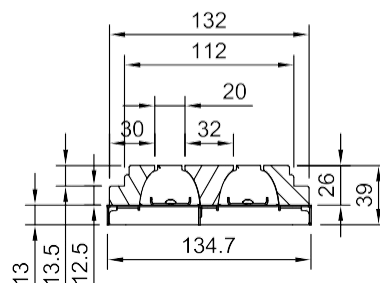
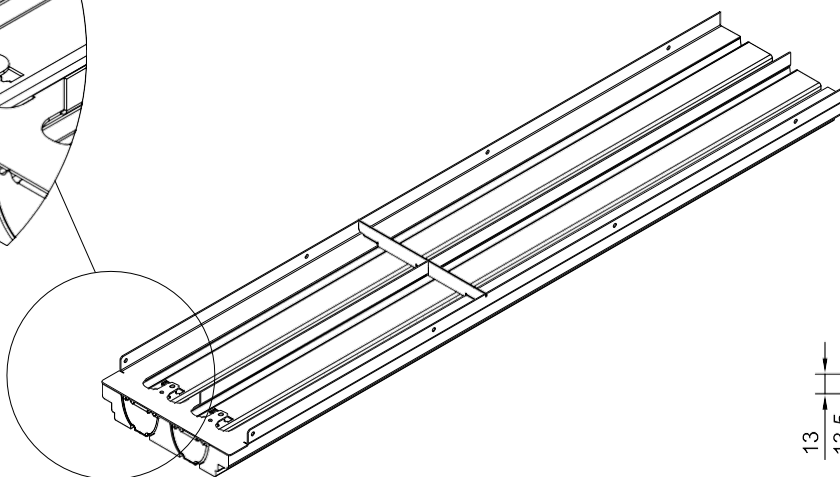
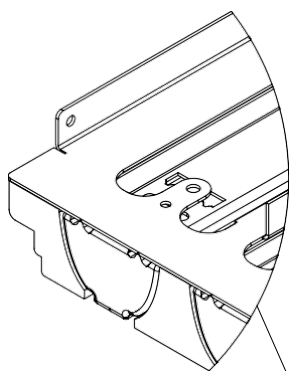

Note: Data charts reflect measurements for the 1 m length model.

PLINE 3/20

PERFORMANCE



3
AMOUNT OF SLOTS

20 mm
WIDTH OF SLOT

5 kg

1 M. LENGTH DIFFUSER WEIGHT
WITHOUT PACKAGING (NET)

625 / 1000 / 1250
STANDARD SLOT LENGTH (MM)

DEFLECTOR OPTIONS:

Standart / Perforated
/ No deflector

C **PLENUM BOX**
WIDTH TYPE

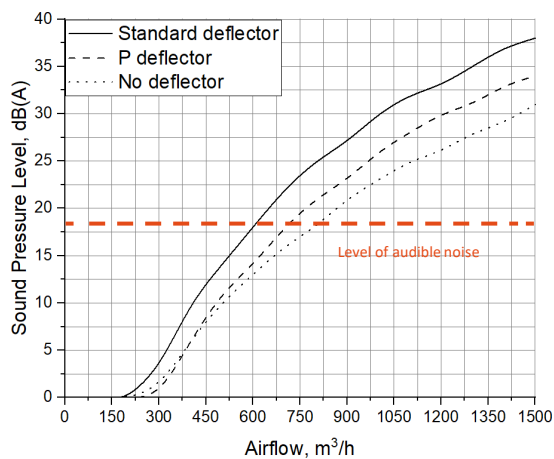
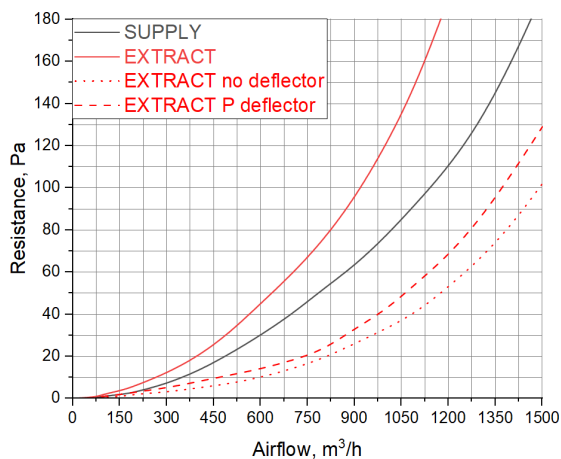
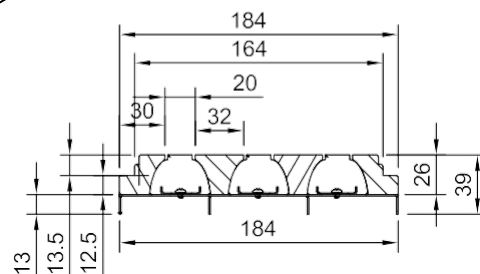
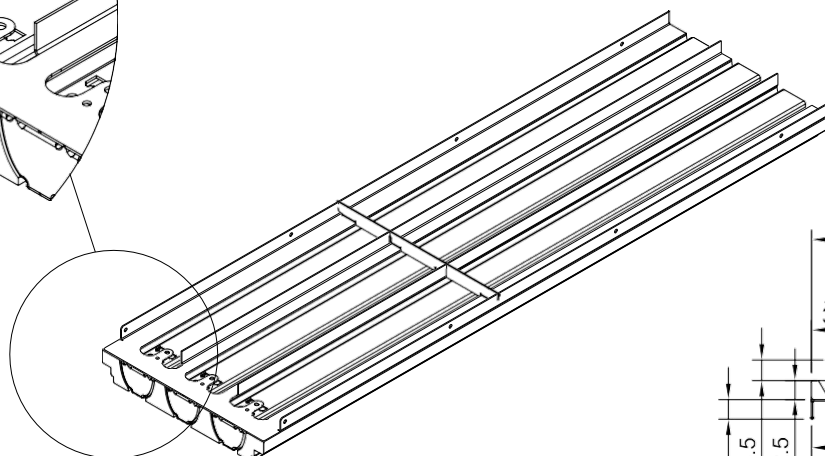
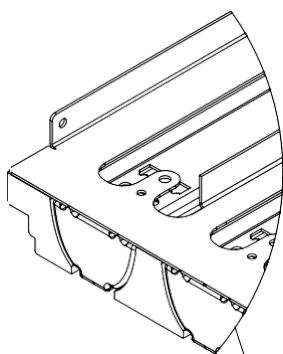

Note: Data charts reflect measurements for the 1 m length model.

PERFORMANCE LINE ACCESSORIES

DEFLECTOR OPTIONS & AIR SUPPLY AFFECT

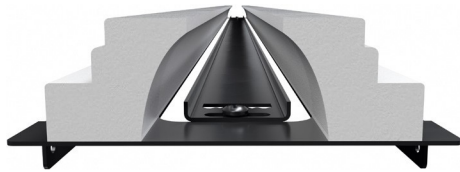

With Deflector

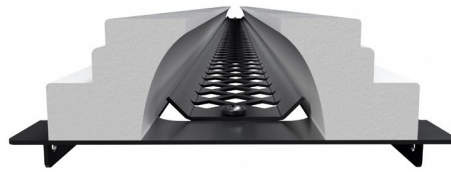

With perforated Deflector

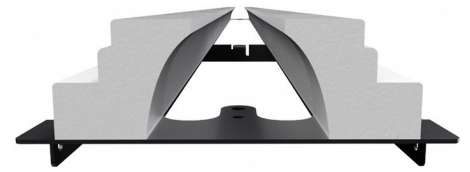

No Deflector

In center position

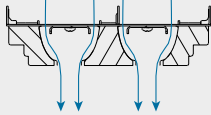

Deflector in left

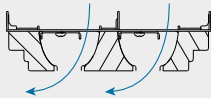

Deflector in right

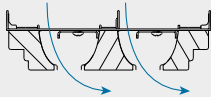

In center position

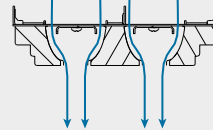

Deflector in left

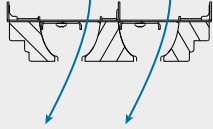

Deflector in right

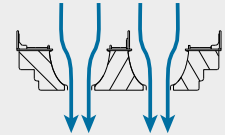
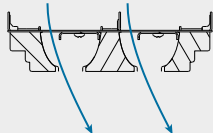

PERFORMANCE LINE FLEXIBILITY

CORRECT END CAP INSTALLATION

The indented arrow shows the correct side how the end cap should be inserted.

WHEN INSTALLING ONE CONTINUOUS LINE

1. The end caps are not used.
2. Two diffusers are installed to each other with a small invisible gap which is then filled with plaster.
3. After plastering and sanding you have one continuous line.

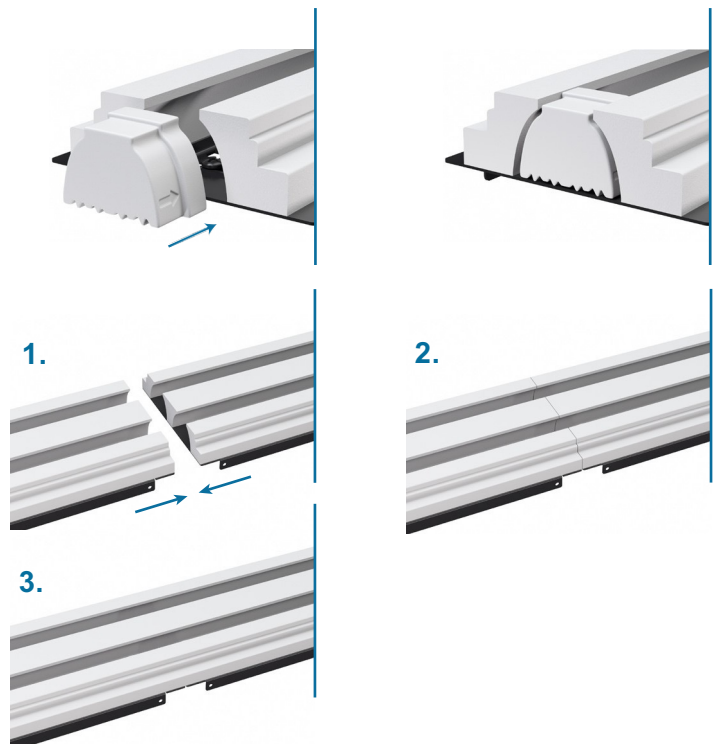

**SUITABLE FOR LINE AND LINE PERFORMANCE DIFFUSERS:
1/12, 1/18, 2/12, 2/18, 1/20 P**

“V” SHAPE INSULATED

Order code:
VTBOX A 125 625

Box width type Hole diameter Box length

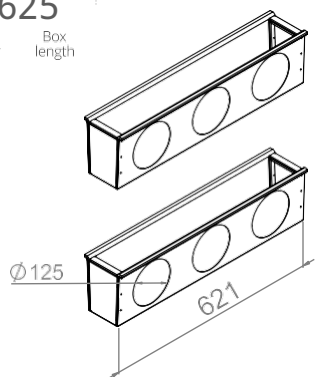

Order code:
VTBOX A 160 625

Box width type Hole diameter Box length

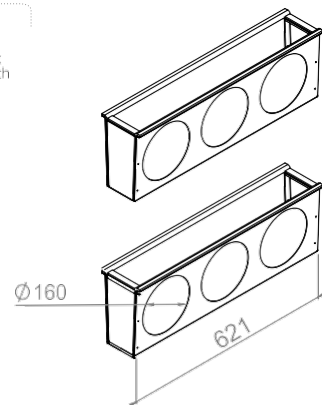

Order code:
VTBOX A 125 1000

Box width type Hole diameter Box length

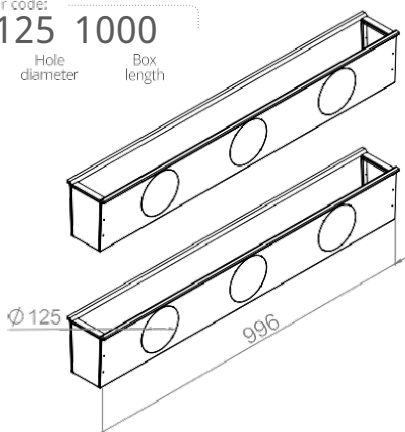

Order code:
VTBOX A 160 1000

Box width type Hole diameter Box length

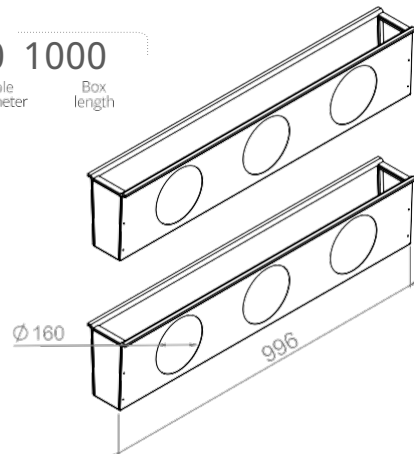

Order code:
VTBOX A 125 1250

Box width type Hole diameter Box length

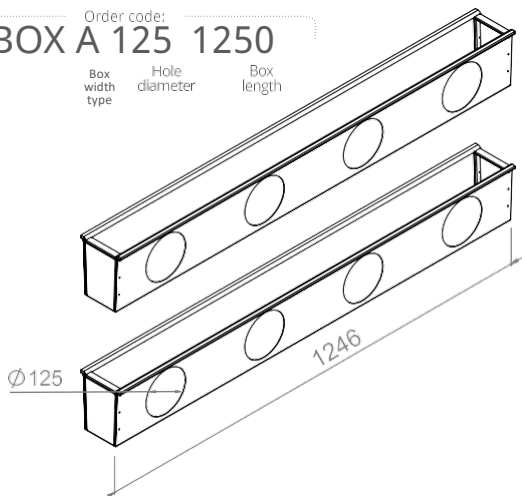

Order code:
VTBOX A 160 1250

Box width type Hole diameter Box length

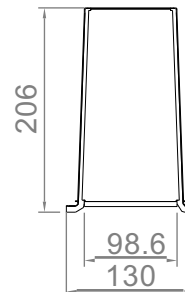
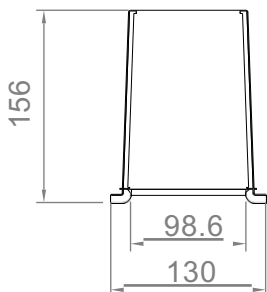
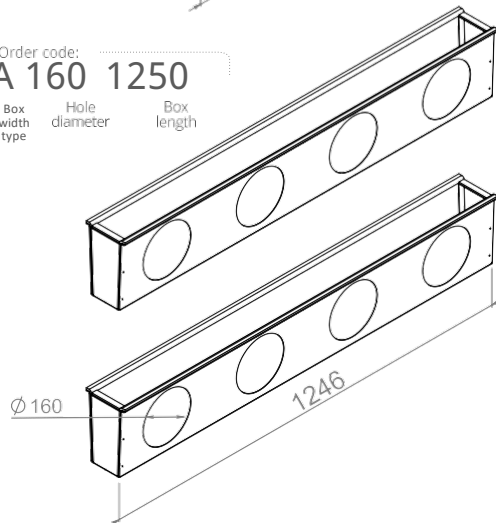

**SUITABLE FOR LINE AND LINE PERFORMANCE DIFFUSERS:
3/12, 3/18, 2/20 P**

“V” SHAPE INSULATED

Order code:
VTBOX B 125 625

Box width type Hole diameter Box length

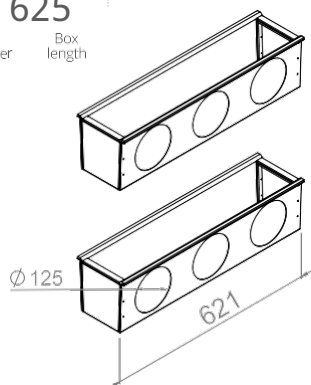

Order code:
VTBOX B 160 625

Box width type Hole diameter Box length

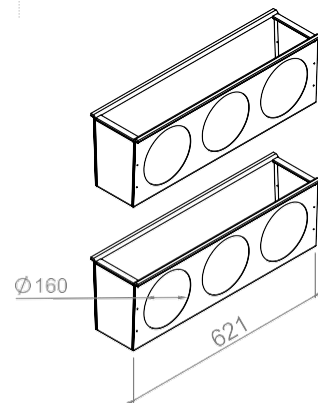

Order code:
VTBOX B 125 1000

Box width type Hole diameter Box length

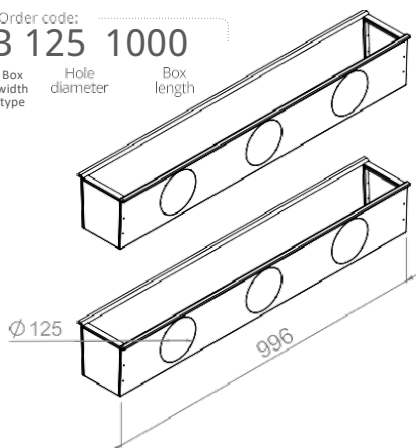

Order code:
VTBOX B 160 1000

Box width type Hole diameter Box length

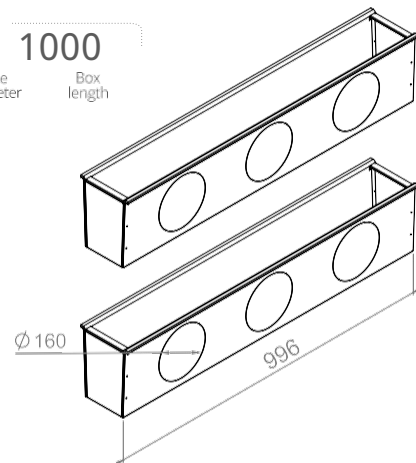

Order code:
VTBOX B 125 1250

Box width type Hole diameter Box length

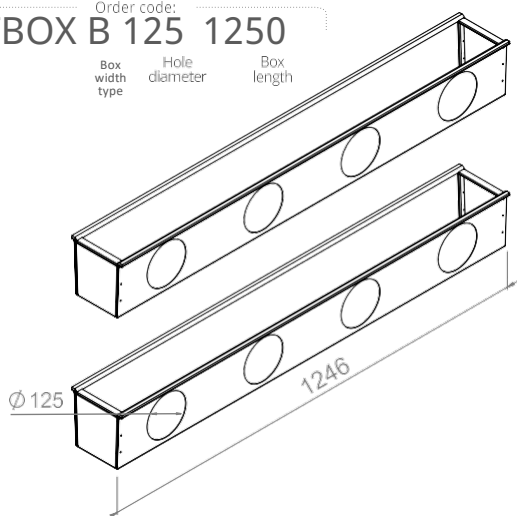

Order code:
VTBOX B 160 1250

Box width type Hole diameter Box length

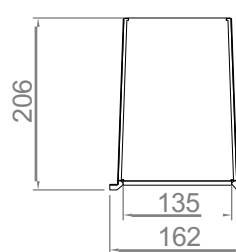
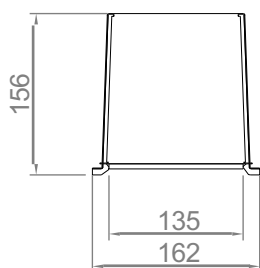
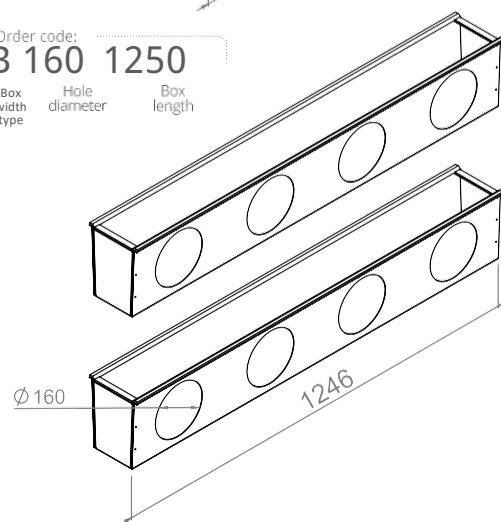

PLENUM BOXES FOR LINE / PLINE DIFFUSERS

C PLENUM BOX
WIDTH TYPE

“V” SHAPE INSULATED

Order code:
VTBOX C 160 625

Box width type Hole diameter Box length

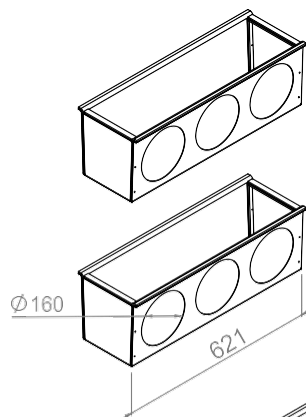

Order code:
VTBOX C 160 1000

Box width type Hole diameter Box length

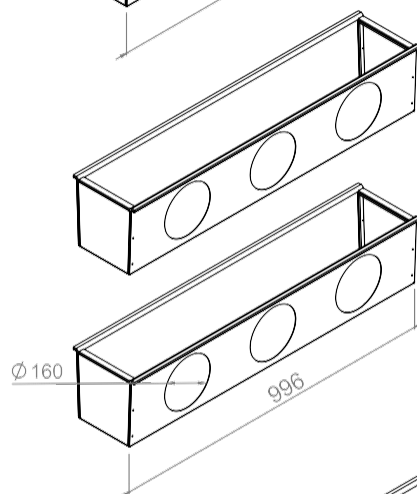

Order code:
VTBOX C 160 1250

Box width type Hole diameter Box length

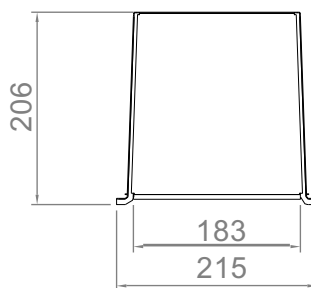
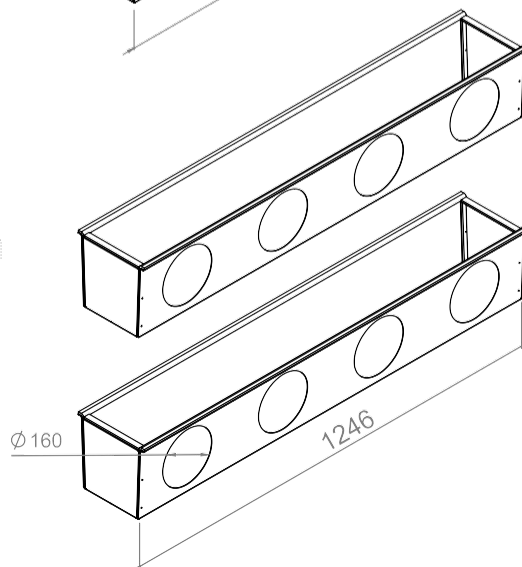

SUITABLE FOR LINE AND LINE PERFORMANCE DIFFUSERS: 3/20 P

Order code:
VTBOX C 200 625

Box width type	Hole diameter	Box length
----------------	---------------	------------

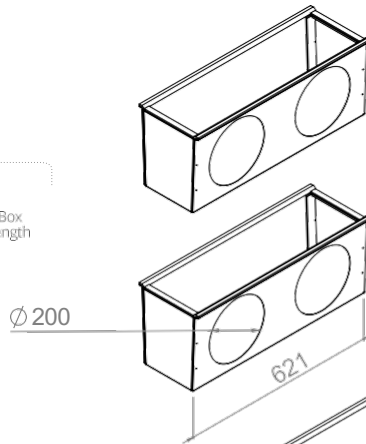

Order code:
VTBOX C 200 1000

Box width type	Hole diameter	Box length
----------------	---------------	------------

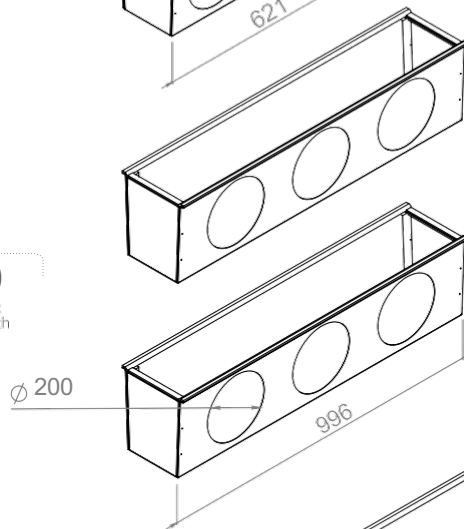

Order code:
VTBOX C 200 1250

Box width type	Hole diameter	Box length
----------------	---------------	------------

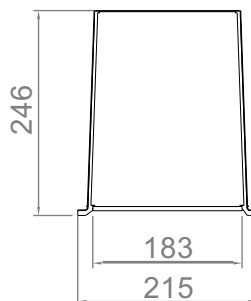
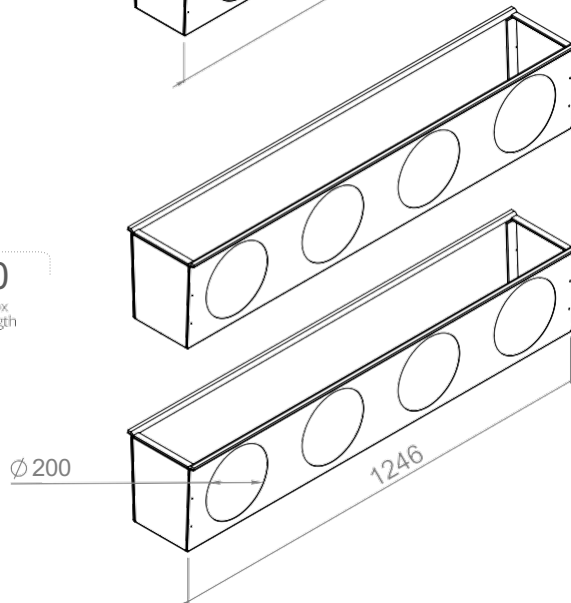

CIRCLE



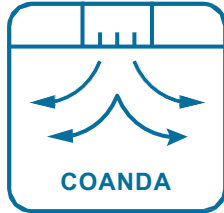

The Ventmann Frameless CIRCLE vent diffusers is a highly versatile solution for every room type and interior design style. Its stylistic dexterity and ability to blend in perfectly with the environment make it our most popular model.

Like all Ventmann vent diffusers, every version of the CIRCLE model can be plastered together with the wall or the ceiling, and the same paint can be applied. This enables a new level of elegance and seamless integration for our ventilation systems.

Our standard CIRCLE model is available with a variety of connection nozzle sizes:

- the smallest connection nozzle diameters available are 100mm or 125mm.
- the mid-sized option for connection nozzle diameter is 160mm.
- and the largest connection nozzle diameters available are 200mm or 250mm.

The diffuser cap is supported by our new Click system. This system makes it even easier to put the cap in place correctly. It is also more environmentally friendly and has a higher operational temperature range than the magnets previously used.

These beautiful, sleek diffusers create a stunning effect, especially when multiple units are installed in a single room.

To see for yourself, and learn more about how these diffusers are installed, you can watch our product showcase video using the QR code below.

You can also find all of the technical information on our CIRCLE vent diffusers in our catalogue.

Ventmann – your choice of air elegance.



LINE / PLINE



CIRCLE / PCIRCLE



SQUARE



ART



Installation:
video instructions



YouTube



Download a digital
version of the catalog



Download

CIRCLE, PCIRCLE & SQUARE SERIES TECHNICAL PARAMETERS

SUPPLY

m ³ /h	dim (mm)	CIRCLE 100/125	SQUARE 100/125	P CIRCLE 125	P CIRCLE 160-1	P CIRCLE 160-2	P CIRCLE 200-1	P CIRCLE 200-2
	Ak (m ²)	0.00589	0.00589	0.00445	0.00939	0.0143	0.0109	0.0174
60	X (m)	2.9	2.3	0.9				
	Pt (Pa)	12	12	18				
	SPLA (dB (A))	<20	<20	<20				
80	X (m)	3.9	3.1	1.2	0.6		0.4	
	Pt (Pa)	22	21	34	4		3	
	SPLA (dB (A))	<20	<20	<20	<20		<20	
100	X (m)	4.9	3.8	1.5	0.7	0.5	0.5	0.4
	Pt (Pa)	34	32	62	7	3	5	2
	SPLA (dB (A))	<20	<20	<20	<20	<20	<20	<20
160	X (m)	7.8	6.2		1.2	0.9	0.8	0.7
	Pt (Pa)	84	85		20	5	11	3
	SPLA (dB (A))	21	21		<20	<20	<20	<20
200	X (m)	9.8	8		1.5	1.1	1	0.9
	Pt (Pa)	149	149		32	7	18	5
	SPLA (dB (A))	25	25		<20	<20	<20	<20
300	X (m)				2.2	1.6	1.5	1.3
	Pt (Pa)				72	17	41	10
	SPLA (dB (A))				26	<20	24	<20
400	X (m)				3	2.2	2.1	1.8
	Pt (Pa)				145	32	71	17
	SPLA (dB (A))				32	25	30	22
500	X (m)					2.7		2.2
	Pt (Pa)					52		27
	SPLA (dB (A))					30		27
600	X (m)					3.2		2.6
	Pt (Pa)					77		39
	SPLA (dB (A))					34		30
700	X (m)							3.1
	Pt (Pa)							54
	SPLA (dB (A))							34

X (m) - Throw distance (0,25 m/s)

Pt (Pa) - Pressure drop in the diffuser

SPLA (dB(A)) - Sound pressure level at 1m distance
from the diffuser

Ak (m²) - effective area

	Green	Yellow	Red
X (m)	When short throw distance is needed	When average throw distance is needed	When bigger throw distance is needed
Pa	Where low pressure drop is required	Where medium pressure drop is suitable	Where big pressure drop is suitable
SPLA	Rooms with no ambient noise (Bedroom)	Rooms with medium ambient noise (Lobby)	Rooms with ambient noise (Office room)

* IMPORTANT: This information is for guidance only, please consult your HVAC professional for you specific requirements.

EXHAUST

m ³ /h	dim (mm)	CIRCLE 100/125	SQUARE 100/125	P CIRCLE 125	P CIRCLE 160-1	P CIRCLE 160-2	P CIRCLE 200-1	P CIRCLE 200-2
	Ak (m ²)	0.00589	0.00589	0.00445	0.00939	0.0143	0.0109	0.0174
60	X (m)							
	Pt (Pa)	12	13	17				
	SPLA (dB (A))	<20	<20	<20				
80	X (m)							
	Pt (Pa)	23	24	32	8		4	
	SPLA (dB (A))	<20	<20	<20	<20		<20	
100	X (m)							
	Pt (Pa)	35	35	55	12	5	6	2
	SPLA (dB (A))	<20	<20	<20	<20	<20	<20	<20
160	X (m)							
	Pt (Pa)	87	90		27	12	14	6
	SPLA (dB (A))	21	21		<20	<20	<20	<20
200	X (m)							
	Pt (Pa)	158	161		42	18	21	9
	SPLA (dB (A))	25	25		<20	<20	<20	<20
300	X (m)							
	Pt (Pa)				93	38	47	21
	SPLA (dB (A))				26	<20	24	<20
400	X (m)							
	Pt (Pa)					64		35
	SPLA (dB (A))					25		22
500	X (m)							
	Pt (Pa)							53
	SPLA (dB (A))							27
600	X (m)							
	Pt (Pa)							84
	SPLA (dB (A))							30

CIRCLE 100/125

ROUND DIFFUSER



100/125 mm

CONNECTION DIAMETER

2,4 kg

WEIGHT WITHOUT PACKAGING (NET)

Order code for 100 ø:

CIRCLE 100

Hole diameter

Order code for 125 ø:

CIRCLE 125

Hole diameter

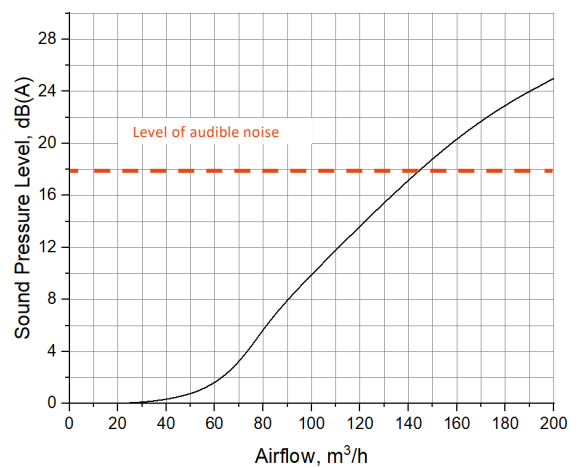
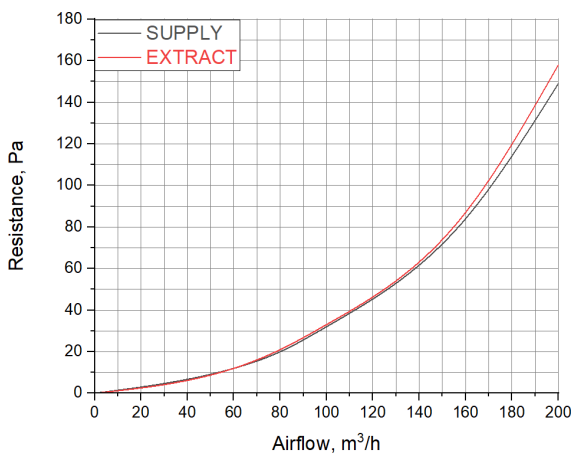
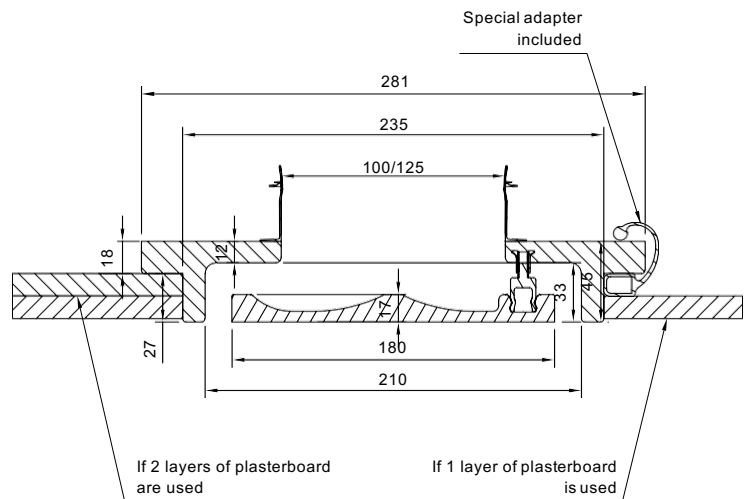
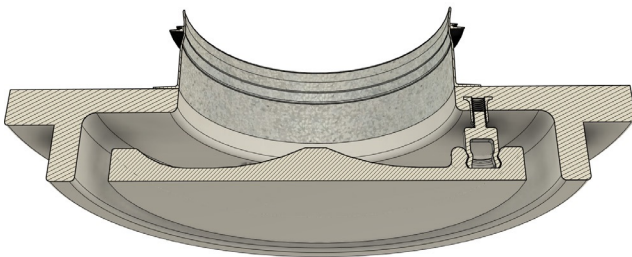

PCIRCLE 100/125

ROUND DIFFUSER „COANDA“

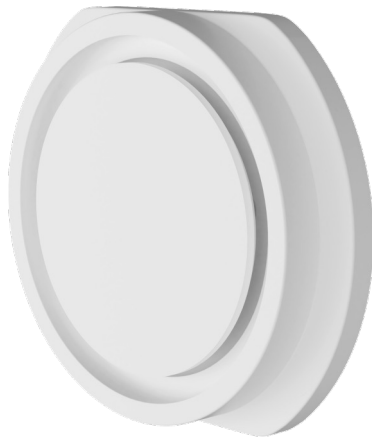

reddot winner 2023

100/125 mm

CONNECTION DIAMETER

2,4 kg

WEIGHT WITHOUT PACKAGING (NET)

COANDA effect

SPECIAL PATENTED SHAPE

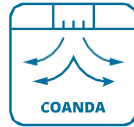

Order code for 100 ø:
PCIRCLE 100
Hole diameter

Order code for 125 ø:
PCIRCLE 125
Hole diameter

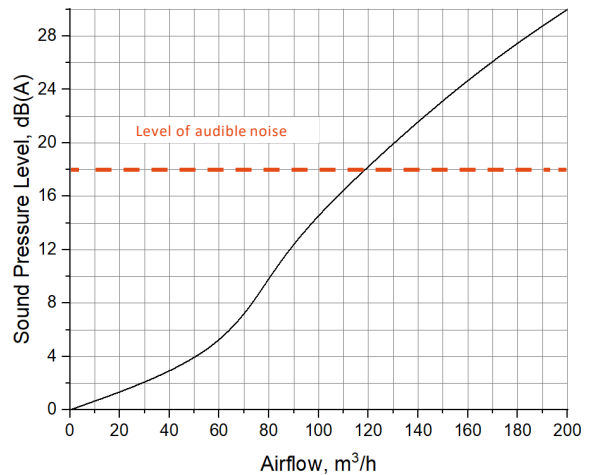
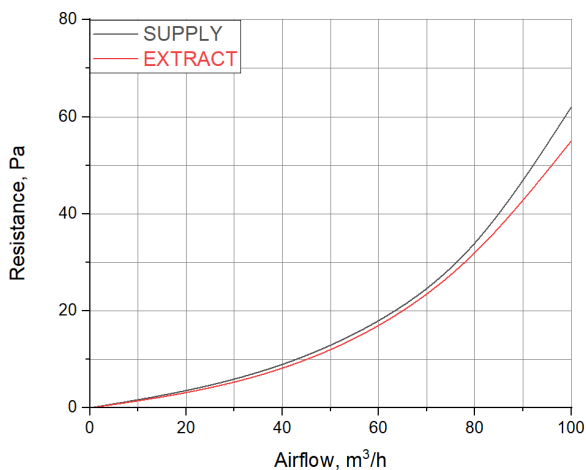
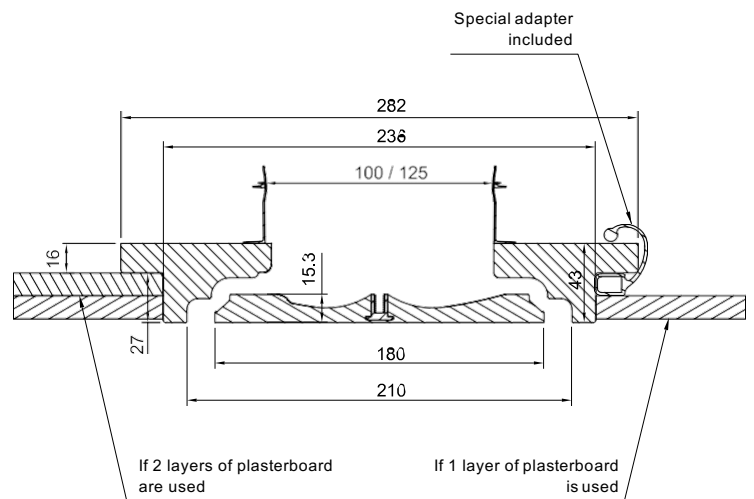
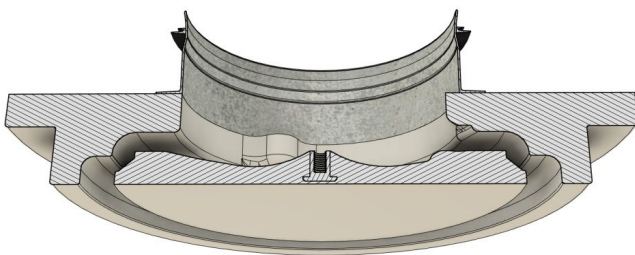

PCIRCLE 1601

ROUND DIFFUSER „COANDA“

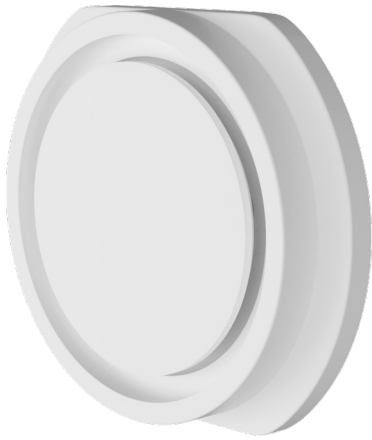

reddot winner 2023

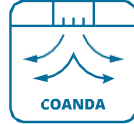

160 mm

CONNECTION DIAMETER

5 kg

WEIGHT WITHOUT PACKAGING (NET)

COANDA effect

SPECIAL PATENTED SHAPE

Order code for 1601 ø:
PCIRCLE 1601
Hole diameter

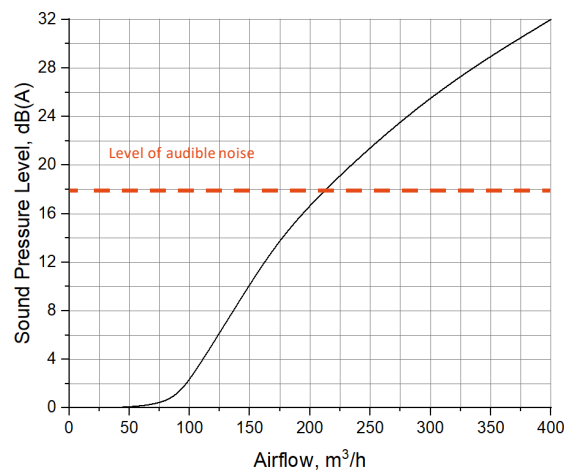
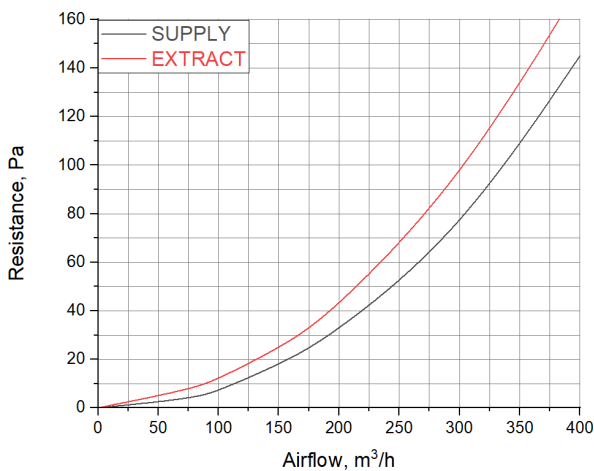
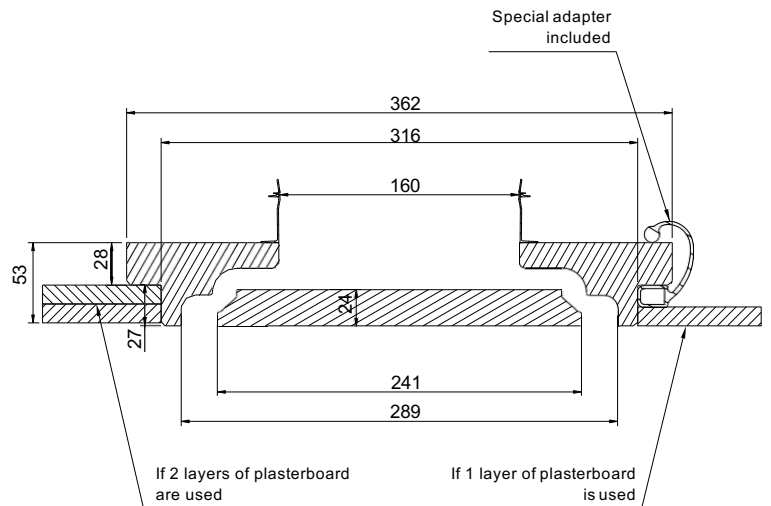
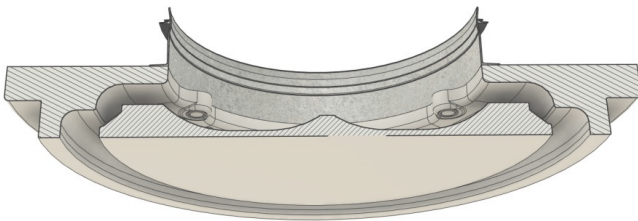

PCIRCLE 1602

ROUND DIFFUSER „COANDA“



Order code for 1602 \varnothing :
PCIRCLE 1602
Hole diameter

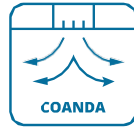

reddot winner 2023

160 mm
CONNECTION DIAMETER

4,85 kg
WEIGHT WITHOUT PACKAGING (NET)

COANDA effect
SPECIAL PATENTED SHAPE

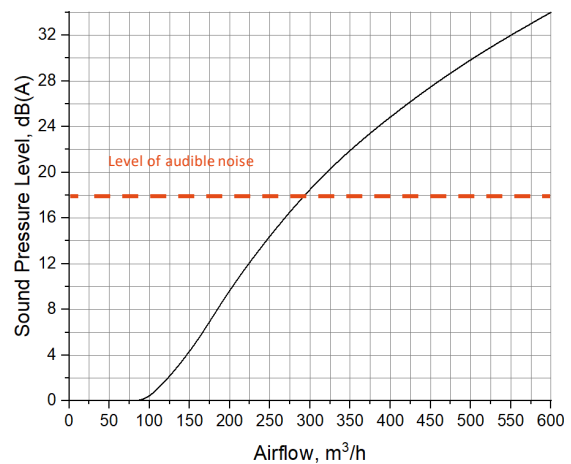
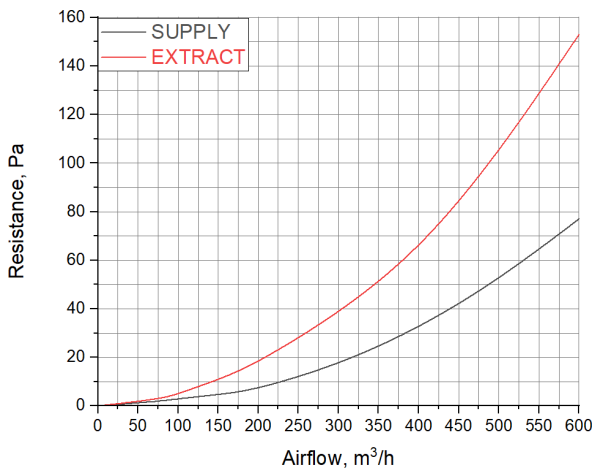
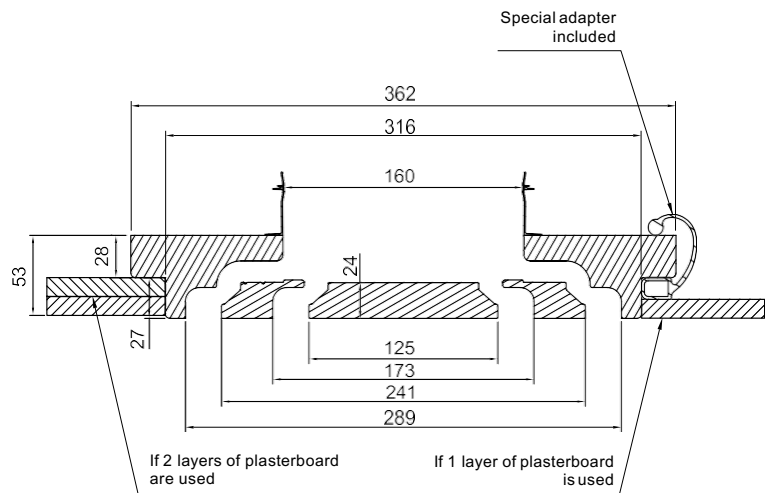
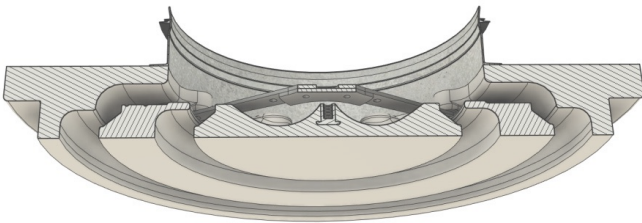

PCIRCLE 2001

ROUND DIFFUSER „COANDA“

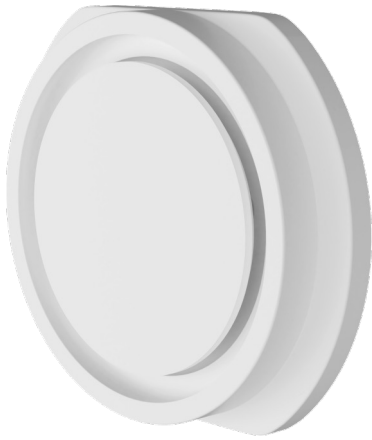

Order code for 2001 ø:
PCIRCLE 2001
Hole diameter

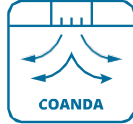

reddot winner 2023

200 mm
CONNECTION DIAMETER

5,75 kg
WEIGHT WITHOUT PACKAGING (NET)

COANDA effect
SPECIAL PATENTED SHAPE

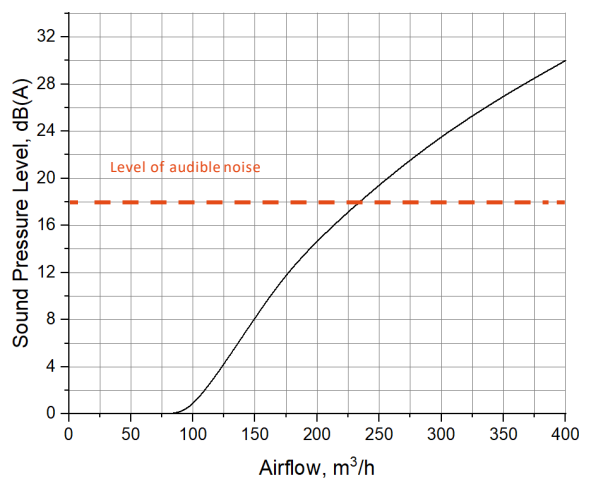
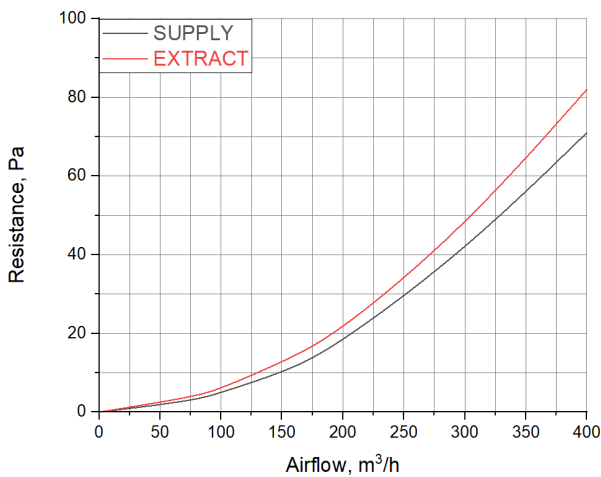
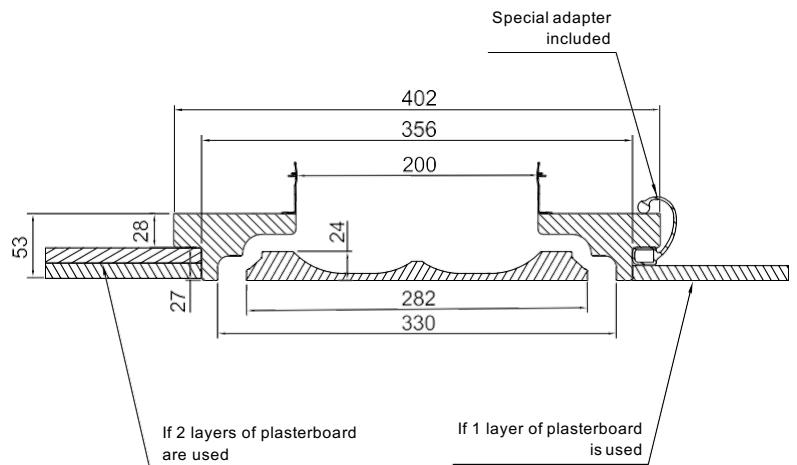
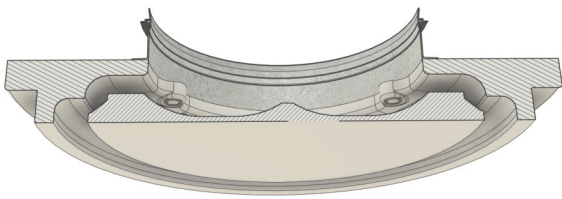

PCIRCLE 2002

ROUND DIFFUSER „COANDA“



Order code for 2002 ø:
PCIRCLE 2002
Hole diameter

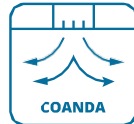

reddot winner 2023

200 mm
CONNECTION DIAMETER

5,55 kg
WEIGHT WITHOUT PACKAGING (NET)

COANDA effect
SPECIAL PATENTED SHAPE

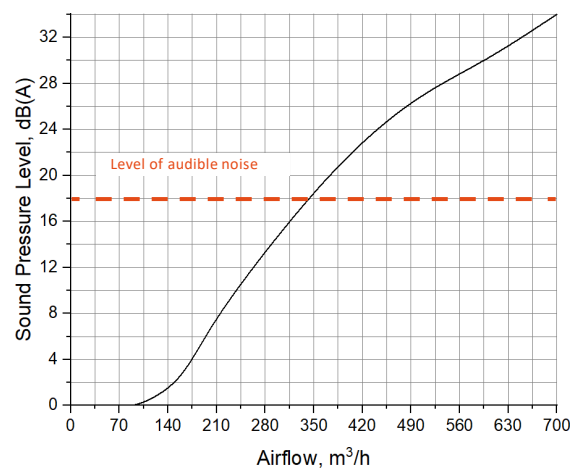
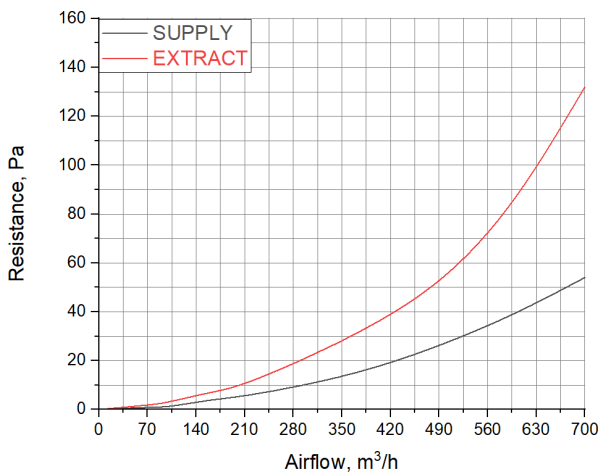
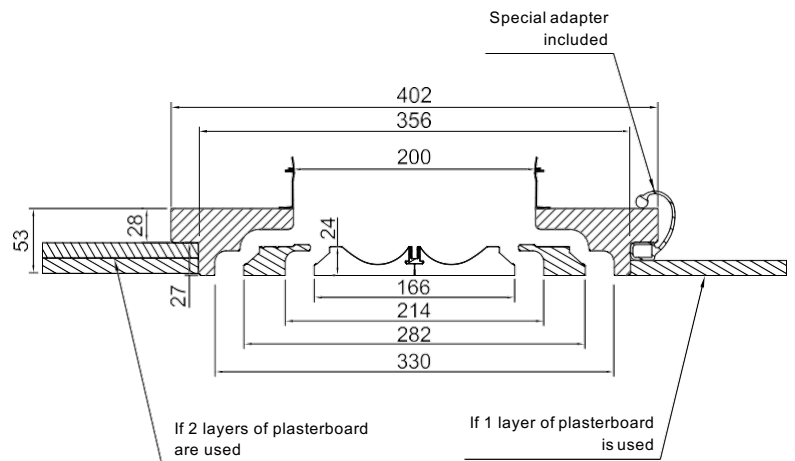
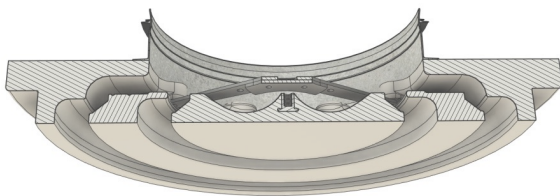

SQUARE



SQUARE

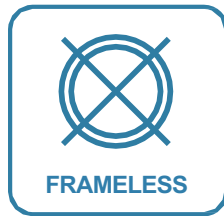

FRAMELESS



PLASTERED-IN



PAINTABLE



The Ventmann SQUARE vent diffuser can act as both an air distributor and a minimalist interior element. It will accentuate the precise lines and rigid angles of your design, with an elegance that means it can be an integral part of any interior.

Due to their well-defined shape, multiple Ventmann SQUARE diffusers can be installed in a single room for an impressive effect.

The Ventmann SQUARE vent diffuser is also a practical solution. Like all of our units, they are mounted at the same time as the walls and ceilings, and can be painted with the same paint. This is all thanks to our unique gypsum composite.

In addition, even standard SQUARE models can be adapted to your needs:

- 100mm or 125mm - these are the standard connection nozzle diameters that you can select.
- The diffuser cap is supported by our new Click system.

This system makes it even easier to put the cap in place correctly. It is also more environmentally friendly and has a higher operational temperature range than the magnets previously used.

If you are looking for non-standard interior details for your project, or your market requires specific SQUARE vent diffuser sizes - we can help you.

To get a look at how these diffusers appear inside an interior, and to understand the installation process, you can watch our product showcase video. Use the QR code below to access it.

You will find all of the technical details you need on the Ventmann SQUARE vent diffuser in our catalogue, and our consultants are ready to answer any questions you might have.

Ventmann – your choice of air elegance.



LINE / PLINE



CIRCLE / PCIRCLE



SQUARE



ART



Installation:
video instructions



YouTube



Download a digital
version of the catalog



Download

SQUARE 100/125

SQUARE-SLOT DIFFUSER



100/125 mm

CONNECTION DIAMETER

2,40 kg

WEIGHT WITHOUT PACKAGING (NET)

Order code for 100 ϕ :
SQUARE 100
Hole diameter

Order code for 125 ϕ :
SQUARE 125
Hole diameter

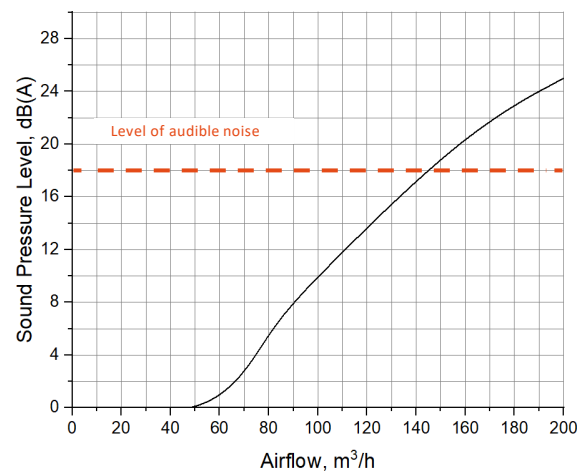
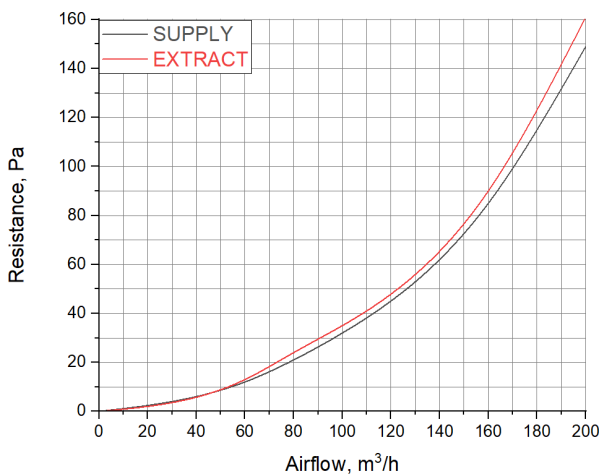
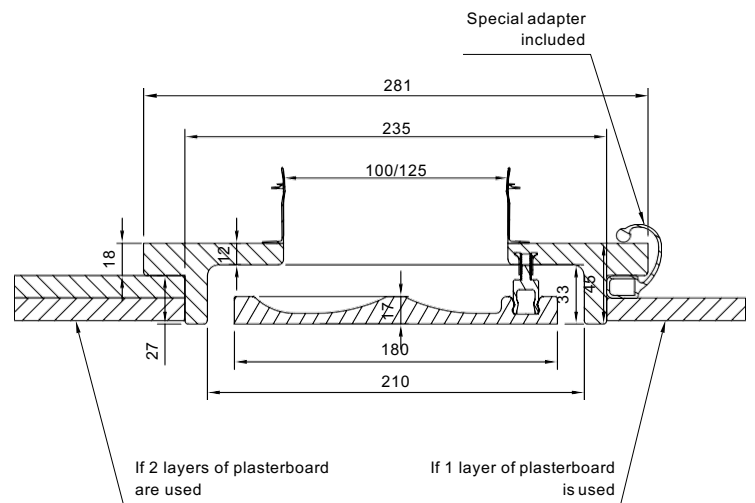
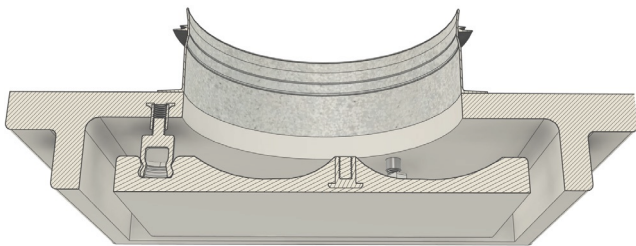

The Ventmann SQUARE vent diffuser is frameless and features a square sloy. It is ideal for a variety of room sizes and spaces, and several units can be deployed in one room.

It can be used for both air supply and air extraction, and can be manufactured with a 100mm or 125mm connection pipe.

SENSIBLE AIRFLOW

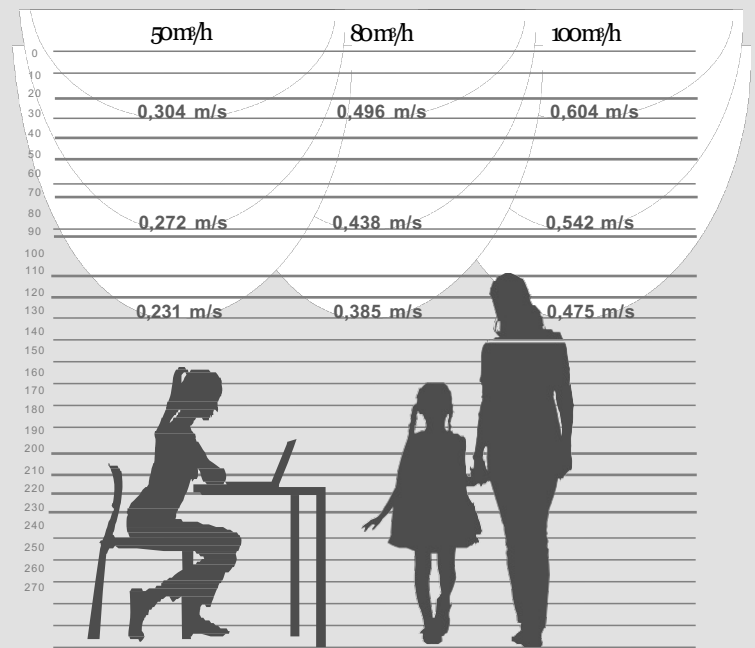

Airflow perceptible with the Square diffuser at a height of 2.70 m

AIR VELOCITY AT DISTANCE FROM DIFFUSER

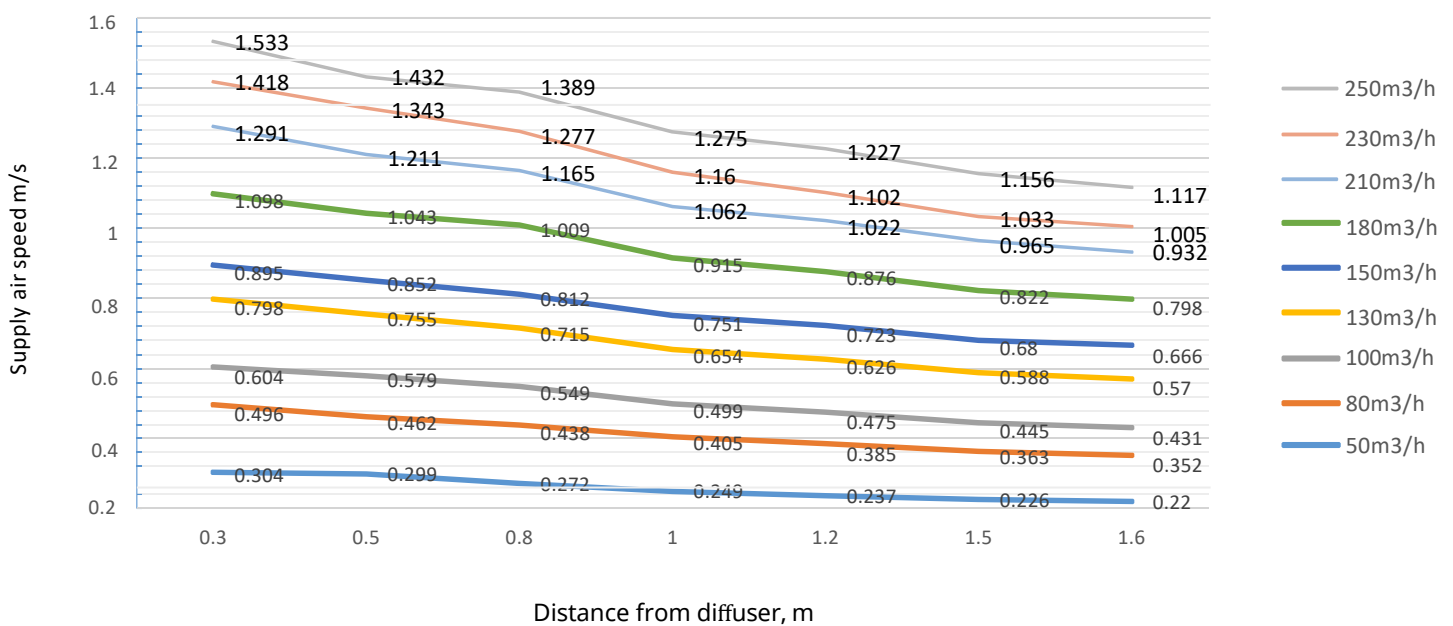

ART





FRAMELESS



PLASTERED - IN



PAINTABLE



The Ventmann ART frameless grill provides an ideal solution for fireplaces, ventilation systems and inspection hatches that seamlessly match classical, high-spec interiors. With size, design, and colour all customisable, these Gypsum grills offer versatility, style and quality.

The inside of these frameless grills is composed of precision laser-cut metal, and the exterior is formed from our special gypsum composite and secured by industrial grade magnets. Using these magnets ensures there are no visible locks or handles, but the grill remains easy to open. This ensures a completely frameless finish to seamlessly integrate with your design.

The Ventmann ART frameless grill:

- comes in white as standard,
- and is available in 3 different styles.

Alternatively, you can also customise the grill to suit your needs exactly:

- it can be produced to your own custom-designed style,
- and it can be made in the colour you require to match your interior.

The grill has a range of potential functionalities. Firstly, it is an ideal option for interior fireplaces and woodburner, providing elegance and character to complement these standout features. Secondly, it provides a stylish option for air vents, especially in classically designed interior spaces. Thirdly, the ART frameless grill can be used as a discrete and aesthetically-pleasing service door or inspection hatch.

Because all custom designs are laser cut, you can choose precisely the amount of permeability you want from your ART grill. For vents, you can select a high level of permeability. Meanwhile, for service doors and hatches the grill can be virtually impermeable.

All our grills are produced using our first-of-its-kind gypsum composite for unrivalled quality. The special formula we use for our gypsum composite ensures it absorbs water well - this means the plaster for the joint sticks well and will not crack later. It can be sanded to a smooth finish, and painted to fit seamlessly with the rest of your interior.

Ventmann - your choice of air elegance.



LINE / PLINE



CIRCLE / PCIRCLE



SQUARE



ART



Installation:
video instructions



Download a digital
version of the catalog



ART

FRAMELESS GRILLS

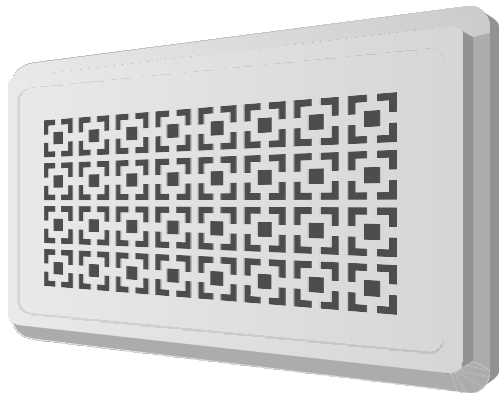

3
DIFFERENT DESIGN STYLES

3
DIFFERENT SIZES

1.2 kg
WEIGHT WITHOUT PACKAGING

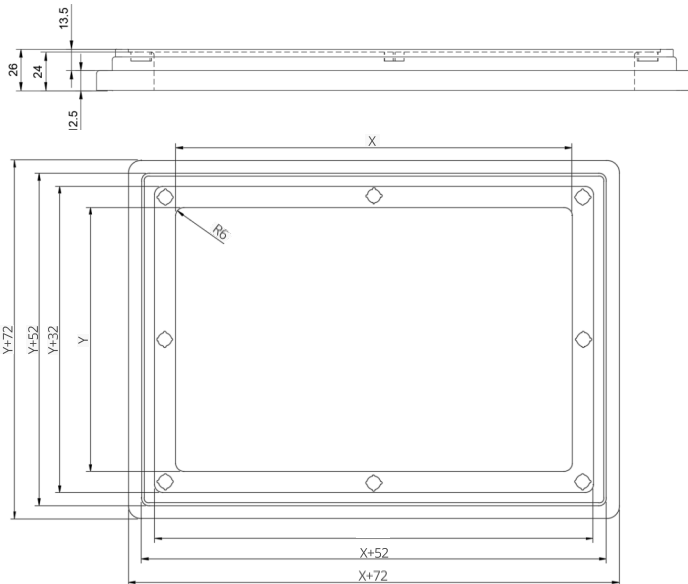

Art grills dimensions

SIZE	X	Y
S	200	100
M	300	200
L	400	300

ART DIFFUSER DESIGN

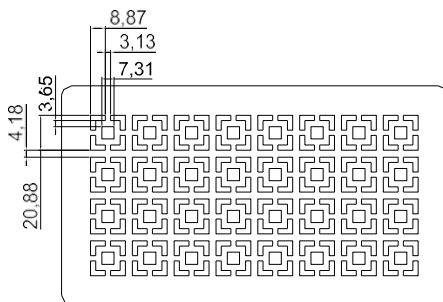

ART 1

Order code example:
ART 1 M W
Design Size Color

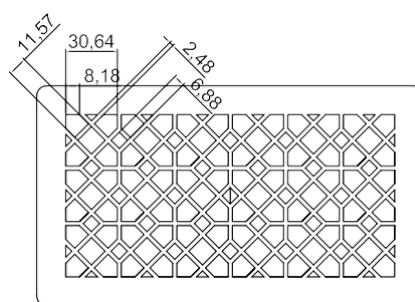

ART 3

Order code example:
ART 3 M W
Design Size Color

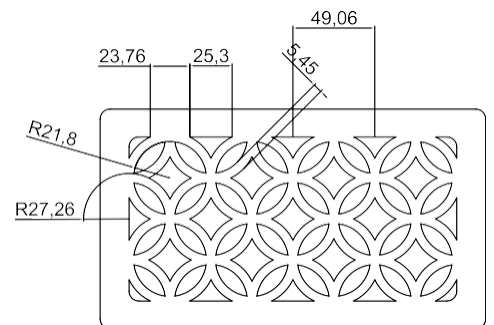

ART 6

Order code example:
ART 6 M W
Design Size Color

These high-spec grills are a great choice for any fireplace, ventilation system or service door in interiors with classical or modern designs. They feature a frameless finish thanks to our unique gypsum composite frame and the use of industrial grade magnets for locking. The grill is available in 3 styles, or the pattern can be custom-designed.

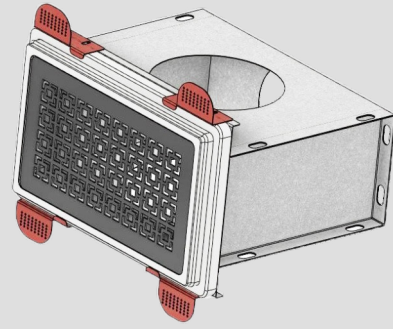

			ART 6
			0,00907
			0,02790
			0,05614

ART GRILLES PLENUM BOX (OPTIONAL)

Dimensions							
SIZE	X	Y	L	W	H	D1	D2
S	200	100	272	172	165	100	125
M	300	200	372	272	200	125	160
L	400	300	472	372	240	160	200

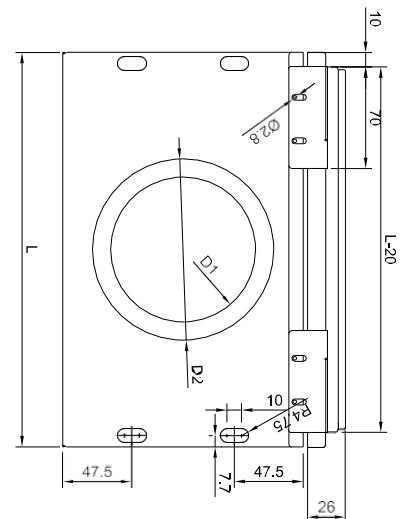
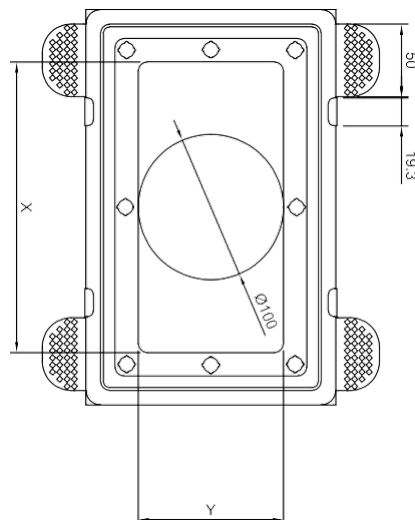
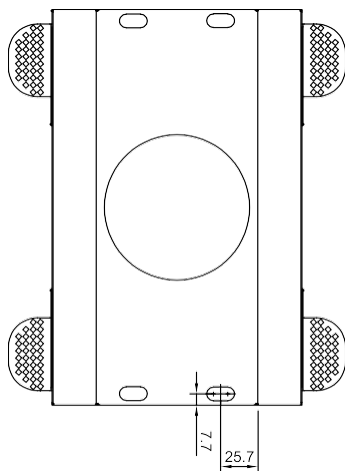
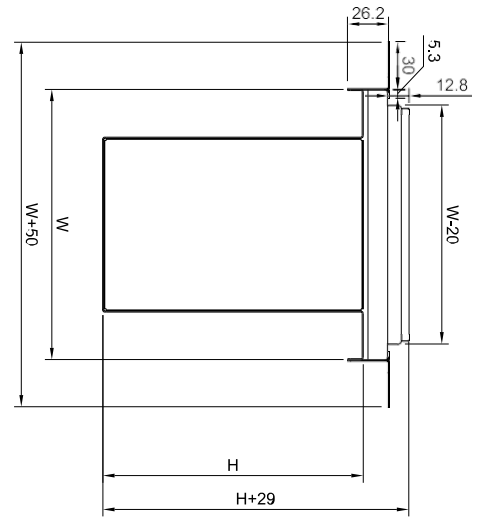

CONTACTS

EMAIL

sales@airdiffusers.co.uk

ADDRESS

Air Diffusers Ltd

*Unit 77, Enterprise Centre Michael Way,
Warth Park Way, Raunds,
NN9 6GR, UK*

WEB PAGE

www.airdiffusers.co.uk

PHONE

0808 123 1213

